

LPC

WEB GUIDE SYSTEM



01

Controller

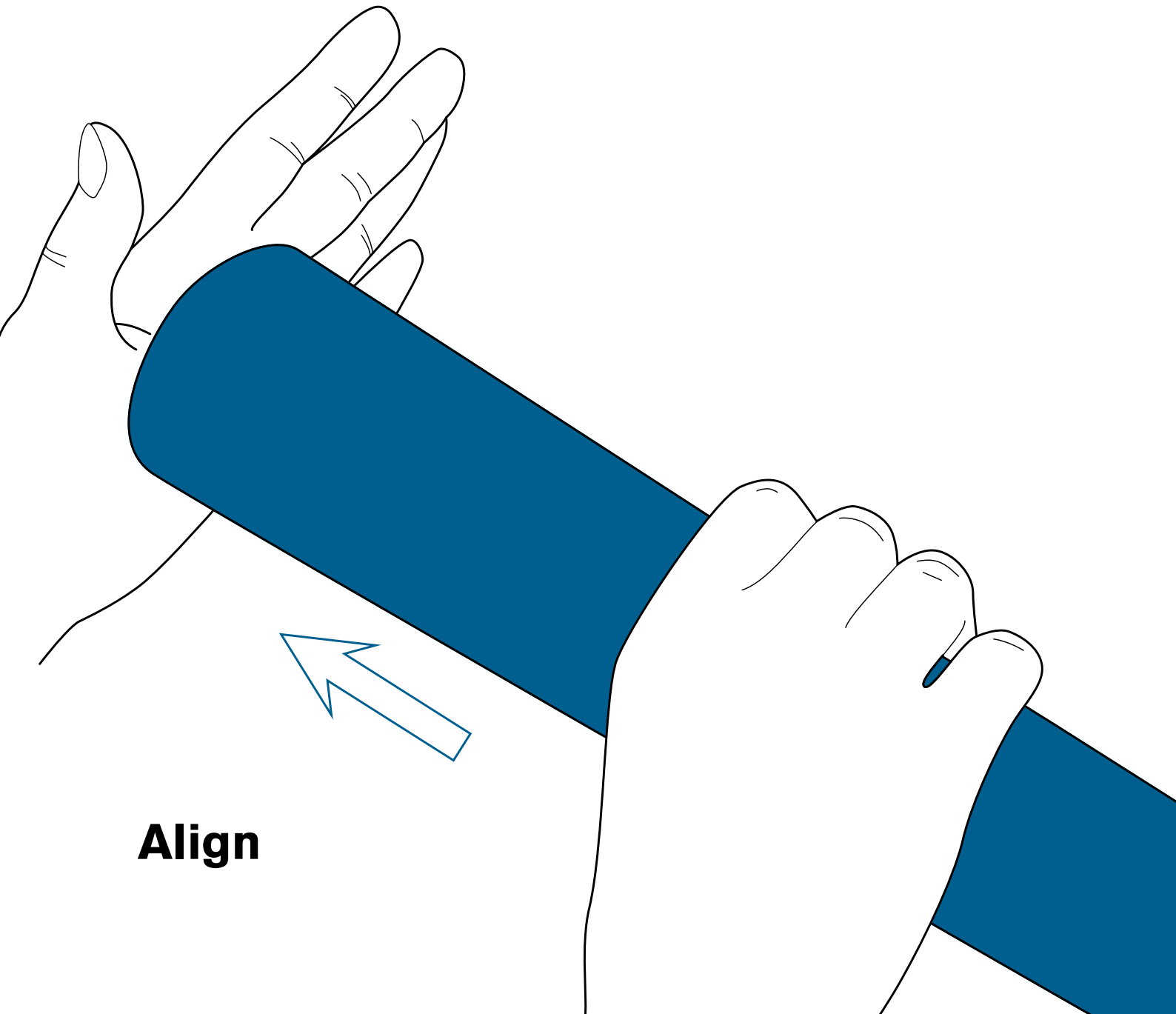

Align

1. LPC Basic System

There are three basic forms in a web guide system.

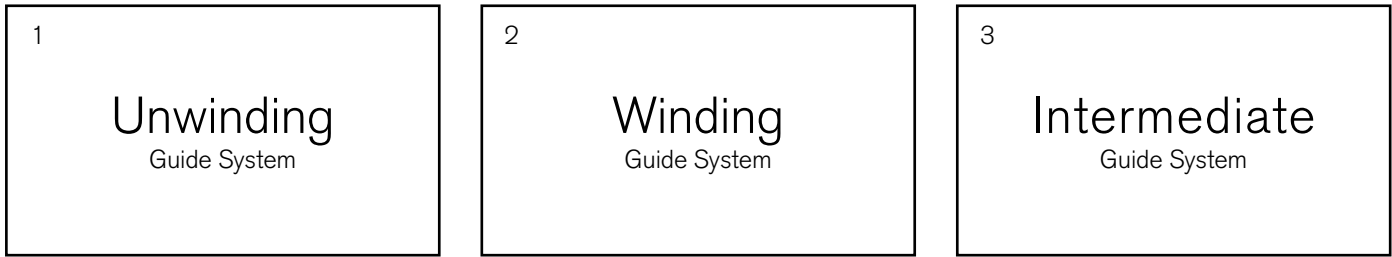

1-1. Unwinding Guide System

A sensor is installed in the conveyance reference position of equipment.
If position gap of the web which begins to be rolled is detected, a reel stand is moved in the correction direction, and a web will always protect a reference position and will be conveyed.

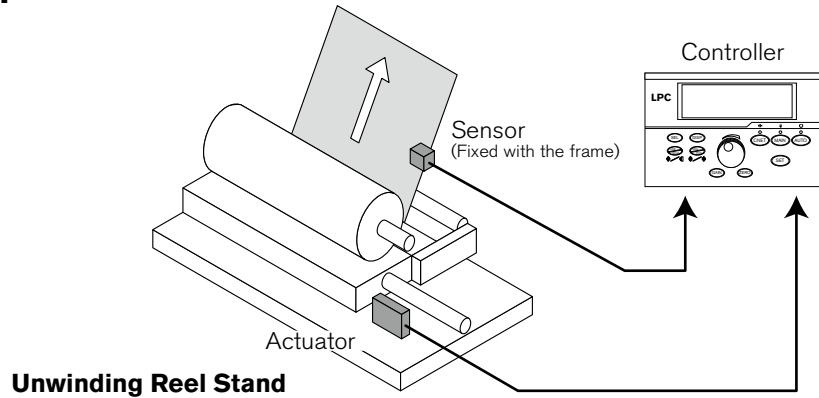

1-2. Winding Guide System

A sensor is installed on the basis of the winding position of a reel stand.
If gap of conveyance of a web is detected, a reel stand will move in the direction which shifted and will arrange the end side of a winding reel.

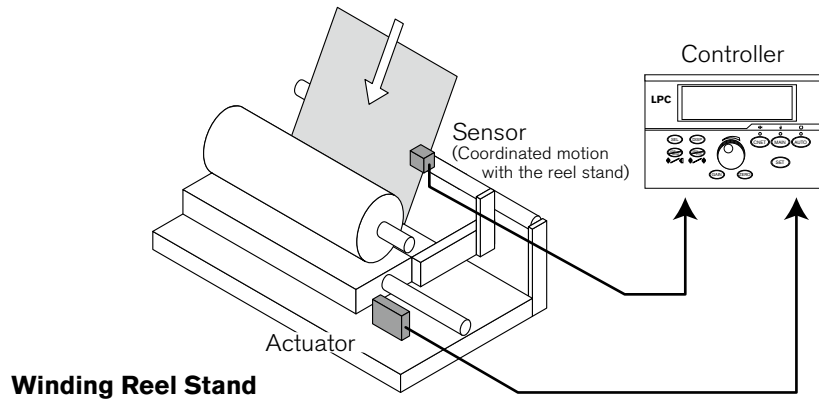

1-3. Intermediate Guide System

When there is a required process of positioning in the middle of conveyance of a web, an intermediate guide system is installed just before that. This corrects gap of conveyance.

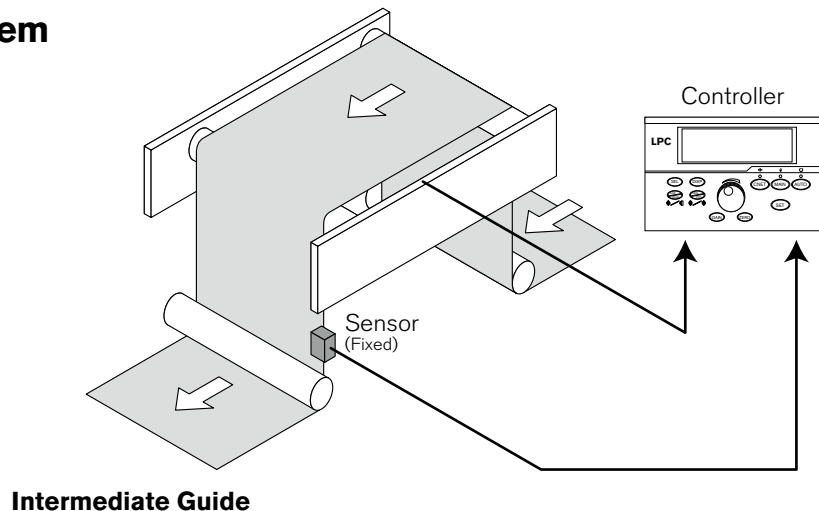

2. Combination of LPC System

Device Configuration

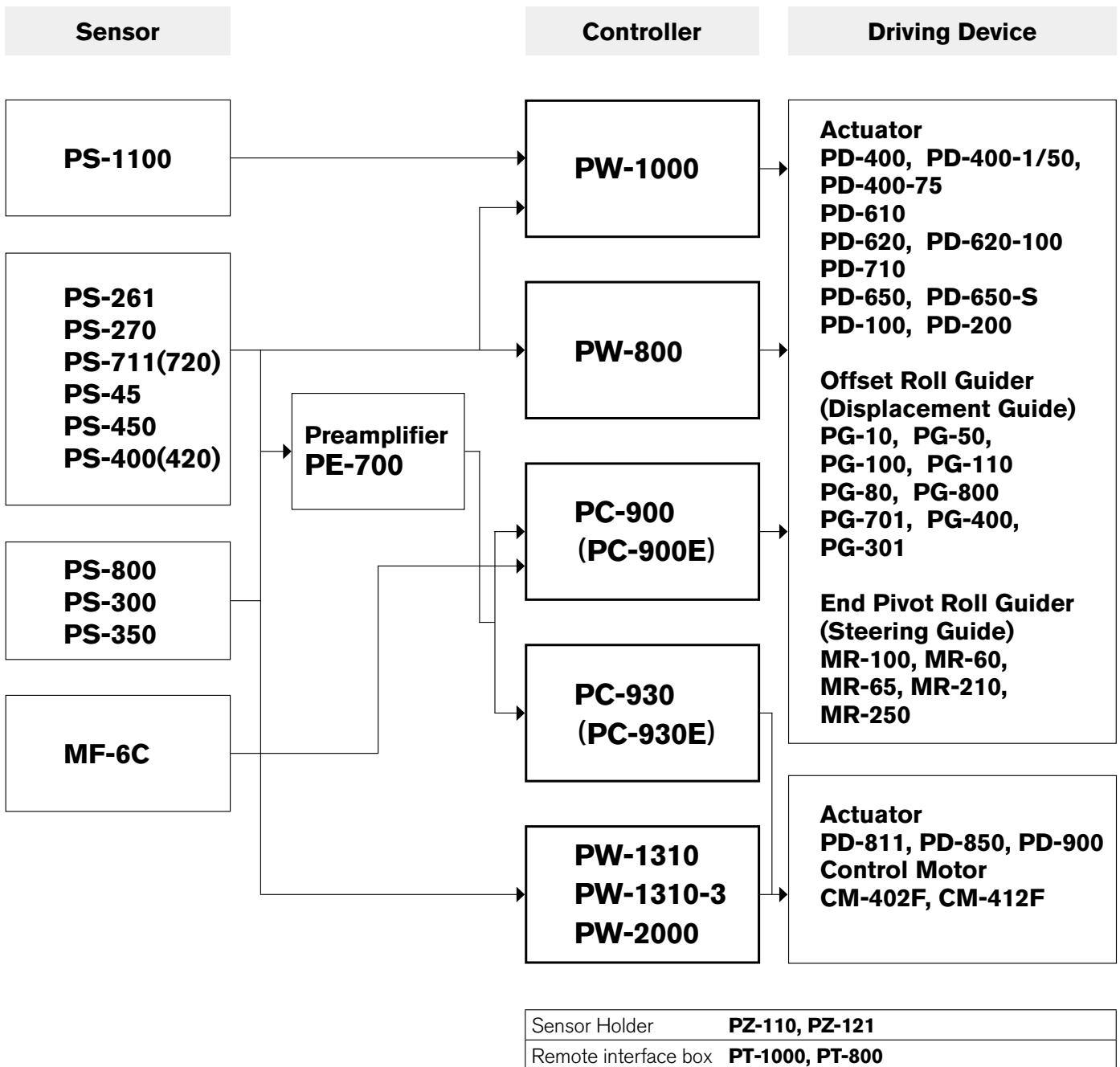

▷ Notes

- LPC units is consisted of Sensors, Control Devices and Driving Devices.
- The detector cord is needed between sensor and Control Device. (option)
- The cord for power supply, motor cord and limit cord are needed to connect the Control Devices and Driving Devices. (option)
- The construction of the controller is such that the Driver are integrated.
For a separate type, Preamplifier and the Driver are combined for use.
- The Remote Boxes are optionally available.

▷ Selection of Units

- Selection of Sensor.....Please select a model of Sensor by the detection target. Please look at a sensor catalog for details.
- Selection of Driving device.....Please select form with the driving method and required capacity.
Please look at a driving device catalog for details.
- Selection of Controller ...By the sensor and the driving device, please choose a combination that can be the controller.

Combination

	Amplifier Integration Type				Amplifier Discretion Type		
	Controller				Preamplifier Driver		
	PW-1000	PW-800	PW-2000	PW-1310	PE-700	PC-900	PC-930
Control Output DC24V	2A	2A	5.5A	15A	DC±10V	2A	15A

Sensor

Model	Type	Target	PW-1000	PW-800	PW-2000	PW-1310	PE-700	PC-900	PC-930
PS-261	Reflection	Line, Edge	○	○ R	○	○	○ R		
PS-270	Reflection	Line, Edge	○	○ R	○	○			
PS-1100	Reflection	Line, Edge	○	○ R	○	○			
PS-711	Transmission	Edge	○	○ T	○	○	○ T	○	○
PS-400/45	Transmission	Edge	○	○ U	○	○	○ U	○	○
PS-800	Transmission	Line, Edge	○		○	○	○ G	(PC-900E)	(PC-930E)
PS-300	Transmission	Edge	○		○	○	○ C	○	○
PS-350	Transmission	Edge	○		○	○	○ C	○	○
MF-6C	Contact Type	EdgeON/OFF/ON						○	○

Remote interface box

Model	Notes	PW-1000	PW-800	PW-2000	PW-1310	PE-700	PC-900	PC-930
PT-1000	PW-1000, PW-1310 exclusive use	○		○	○			
PT-800	PW-800 exclusive use		○					

Driving device

Actuator

Model	DC24V	Thrust N	Stroke mm	Driving Speed mm/s	PW-1000	PW-800	PW-2000	PW-1310	PE-700	PC-900	PC-930
PD-400	DC24V 1.5A	392	50	20	○	○				○	
PD-400-75	DC24V 1.5A	392	75	20	○	○				○	
PD-400-1/50	DC24V 1.4A	1666	50	4	○	○				○	
PD-710	DC24V 1.2A	412	100	13	○	○				○	
PD-610	DC24V 1.5A	490	180	16	○	○				○	
PD-620	DC24V 1.2A	372.4	180	18	○	○				○	
PD-620-100	DC24V 1.2A	372.4	100	18	○	○				○	
PD-650	DC24V 2.4A	1039	180	13	○	○				○	
PD-650S	DC24V 2.4A	980	180	28	○	○				○	
PD-100	DC24V 0.6A	—	210	13	○	○				○	
PD-200	DC24V 1.5A	—	400	13	○	○				○	
PD-811	DC24V 3.8A	1725	180	14			○	○			○
PD-850	DC24V 6A	2744	180	13			○	○			○
PD-900	DC24V 11A	3920	180	16				○			○

Offset Roll Guide(Displacement Guide)

Model	DC24V	Web Speed m/min	Roll Length mm	Roll Span mm	PW-1000	PW-800	PW-2000	PW-1310	PE-700	PC-900	PC-930
PG-10	DC24V 0.4A	100	100~200	50~120	○	○				○	
PG-50	DC24V 0.45A	100(MAX)	100~300	125~200	○	○				○	
PG-100	DC24V 0.4A	100(MAX)	100~300	50~200	○	○				○	
PG-110	DC24V 0.4A	100(MAX)	100~300	50~200	○	○				○	
PG-80	DC24V 0.4A	100(MAX)	100~300	50~200	○	○				○	
PG-800	DC24V 0.4A	100	100~300	50~200	○	○				○	
PG-701	DC24V 0.7A	150(MAX)	300~600	180~400	○	○				○	
PG-400	DC24V 1.5A	300(MAX)	600~1600	200~400	○	○				○	
PG-301	DC24V 2.0A	350(MAX)	800~2000	300~900	○	○				○	

	Amplifier Integration Type				Amplifier Discretion Type		
	Controller				Pre-amplifier Driver		
	PW-1000	PW-800	PW-2000	PW-1310	PE-700	PC-900	PC-930
Control Output DC24V	2A	2A	5.5A	15A	DC±10V	2A	15A

**End pivot Roll Guider
(Steering Guide)**

	Web Speed m/min	Roll Length mm	Roll Span mm								
MR-100	DC24V 0.6A	150 (MAX)	230~600	100~250	○	○				○	
MR-60	DC24V 1.5A	200 (MAX)	800 (MAX)	150~400	○	○				○	
MR-65	DC24V 1.5A	200 (MAX)	300~2000	150~400	○	○				○	
MR-210	DC24V 2A	200 (MAX)	440~2500	150~400	○	○				○	
MR-250	DC24V 2A	200 (MAX)	680~2500	150~400	○	○				○	

Control Motor

		Starting Torque N·cm	Rated Torque N·cm							
CM-402F	DC24V 11A	2744	784 (100rpm)			○				○
CM-412F	DC24V 11A	1372	392 (220rpm)			○				○

The selection method of Sensor

A detector can be divided into an optical reflection type, an optical transmission type, and an ultrasonic transmission type. Detection object (edge, line, pattern) and the web (transparent, opaque, material) and then selected by.

1. A reflection type sensor is mainly used for detection of a line mark. Moreover, detection of the edge of the printed pattern is also possible.
2. A transmission type sensor is mainly used for the edge detection of a web. Depending on a model, a line is also detectable.

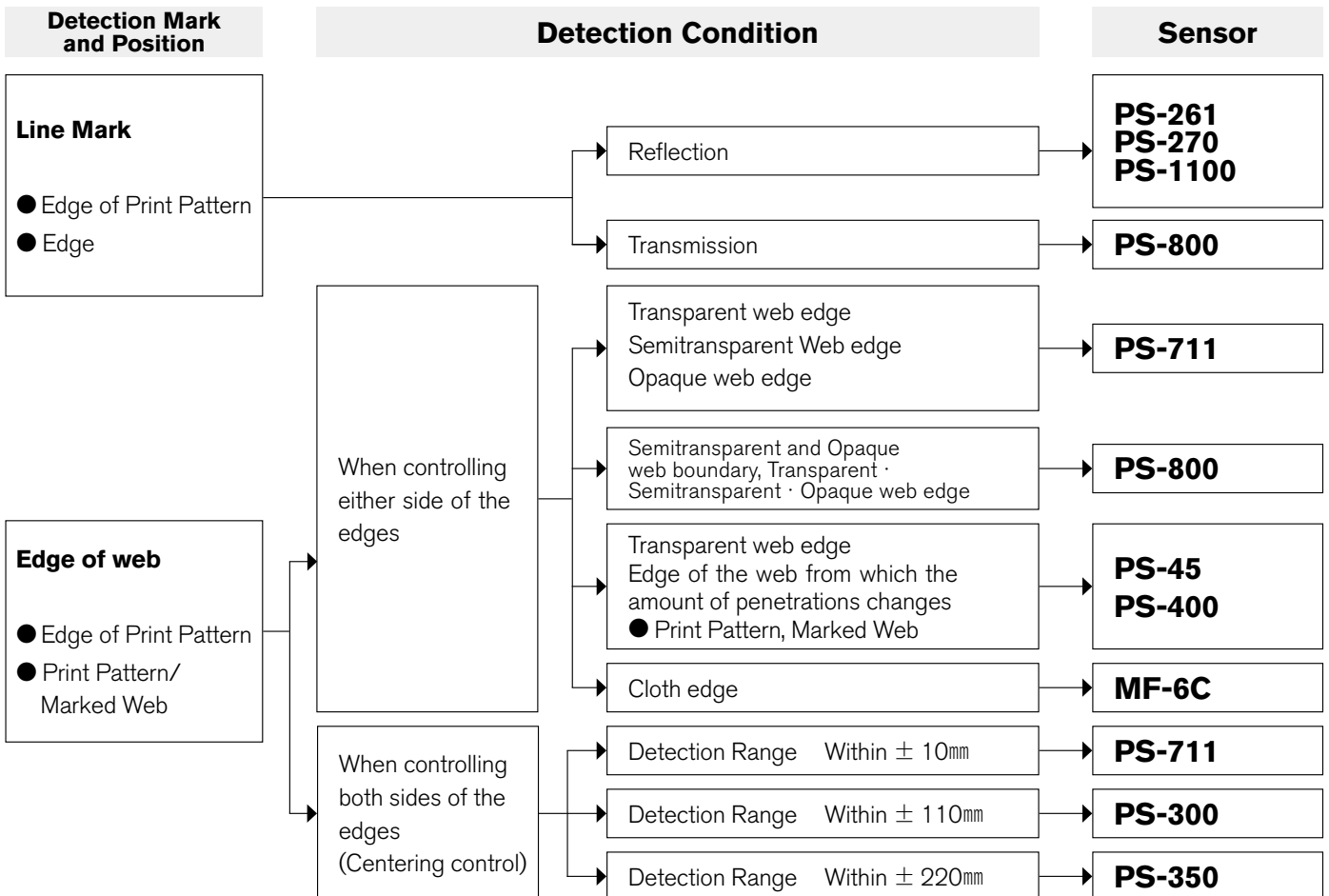

3. Controller

3-1. PW-1000 PW-2000 PW-1300

Feature

1. It corresponds to the standard detector of our company.

It can respond to the standard sensor of our company. PW-1000 and PW2000 are preparing two inputs of a sensor. (PW1310 is one line) The switching control of winding and feeding is possible at one set of PW-1000 and PW-2000 controller. Moreover, it is also possible to connect simultaneously the sensor with which kinds differ and to carry out change use of the optimal sensor for a web.

2. Three bank memories are available

Three bank memories are available for diverse settings. A bank stores the data of applied sensors, gain zero points of others. When using the web of other product, the optimal setup can be

called only by the change of a bank.

3. Large LCD display provided (Eight lines x 40 characters)

Operational status can be checked at a glance. Moreover, the input of a setting item is easy and possible for application at various directions for use.

4. Free power source and energy-saving design

No connection change is required within the power supply range from AC100V~AC200V. The power consumption is minimized. (The power source of PW-1310 is AC200V)

PW-1000

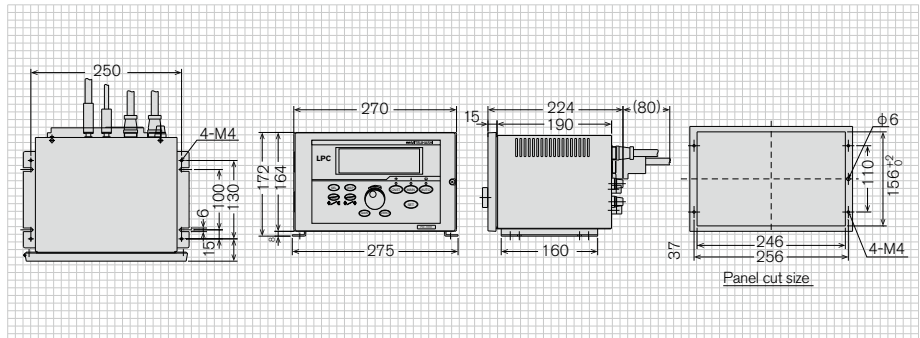

PW-2000

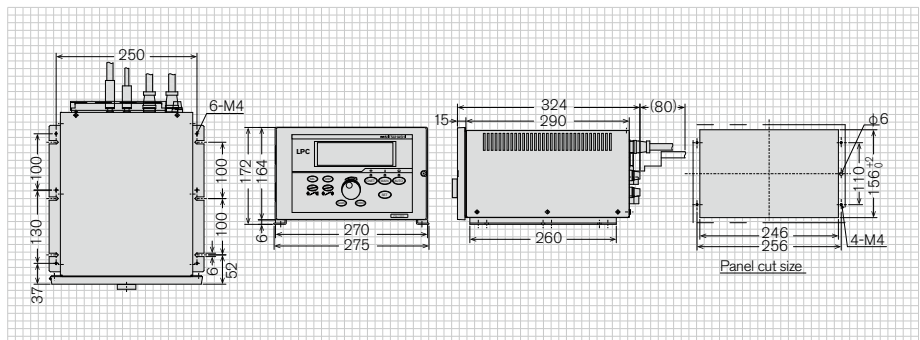

PW-1310

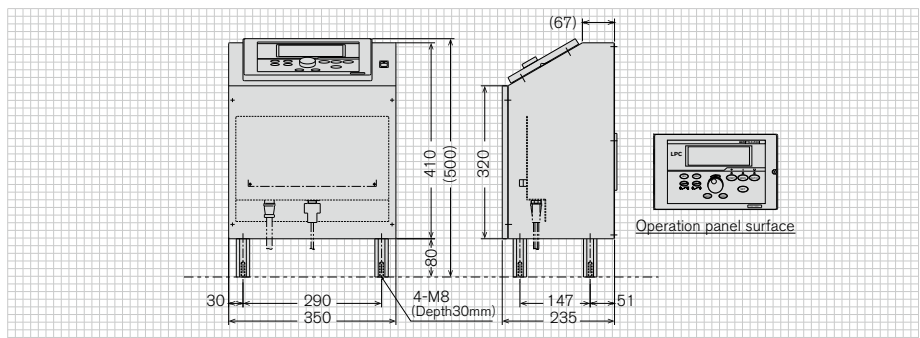

Front Operation Panel

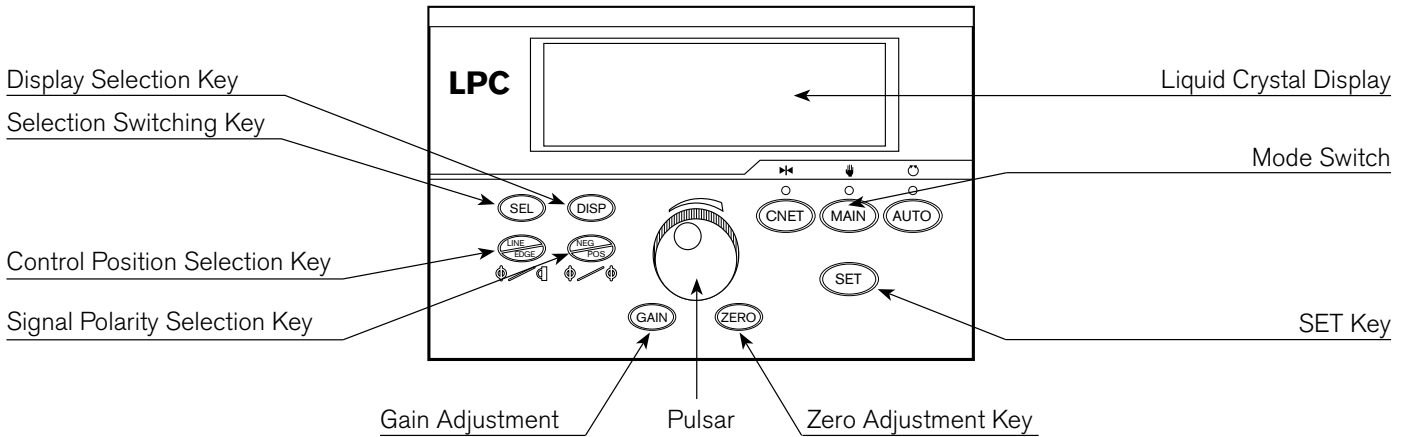

Specification

	PW-1000	PW-2000	PW-1310-3	PW-1310
--	---------	---------	-----------	---------

General Specification

Outline	Panel Size: width 270 × height 164 × depth 206(Built-in Size)	Panel Size: width 270 × height 164 × depth 206(Built-in Size)	width 350 × height 500 × depth 235	width 350 × height 500 × depth 235
Power Supply	Single Phase AC85V~AC264V Free power supply	Single Phase AC85V~AC264V Free power supply	Single Phase AC200V	Single Phase AC200V
Power Consumption	Max. 200VA	Max. 250VA	Max. 600VA	Max. 600VA
Mass	Approx. 5kg	6.5kg	Approx. 25kg	Approx. 25kg
Environment	Ambient Temperature 0 ~ 40°C Humidity Below 80%RH (No condensation)			

Functional Overview

Sensor Inputs	Two Lines (different types coexistence) External Analog Inputs Two Lines		Single Line	
Fitting Sensor	PS-261, PS-270, PS-1100, PS-300, PS-350, PS-400, PS-45, PS-711, PS-800			
Fitting Driving Device	PD-400, PD-400-75, PD-400-1/50, PD-710, PD-610, PD-620, PD-620-100, PD-650, PD-650S, PD-100, PD-200 PG-10, PG-50, PG-80, PG-100, PG-110, PG-701, PG-800, PG-400, PG-301 MR-100, MR-60, MR-65, MR-210, MR-250	PD-811, PD-850	PD-811, PD-850	PD-900, CM-402F, CM-412F
Constitutions of Memory	System memory:1 Bank memory:3 Bank Sensor input channel, EDGE/LINE, POS/NEG, Zero, Gain, Integral action time, Dead band width, Dead band gain			
External Control Input	Mode Select(MAN/CEN/AUT), Balance Set, Manually Driving, Bank Select	_____	_____	_____
External Control Output	During Operation, Mode (MAN/CEN/AUT), Actuator Stroke End, Bank change response, Comparator judge output (option)	_____	_____	_____
Option	Remote interface box.....PT-1000(separately sold) Comparator.....Option at factory			

3-2. PW-800

Feature

1. **Compact control unit** PW-800 controller is compared to our conventional product (PW-1000), the volume was reduced in size to 1/4. Attachment uses for few spaces in the impossible production line, and realizes highly efficient meandering correction until now.
2. **Easy operation** A reference position only presses the SET button and is set up automatically. Sensitivity adjustment can also be made to fluctuate with a switch.
3. **web key adoption** Since the web key is used, dust does not invade from a panel side.

Application Example

It is used for unwinding and winding of the web guides in the middle of conveyance, such as a packaging machine, coater, a laminating machine, and a printing machine.

PW-800

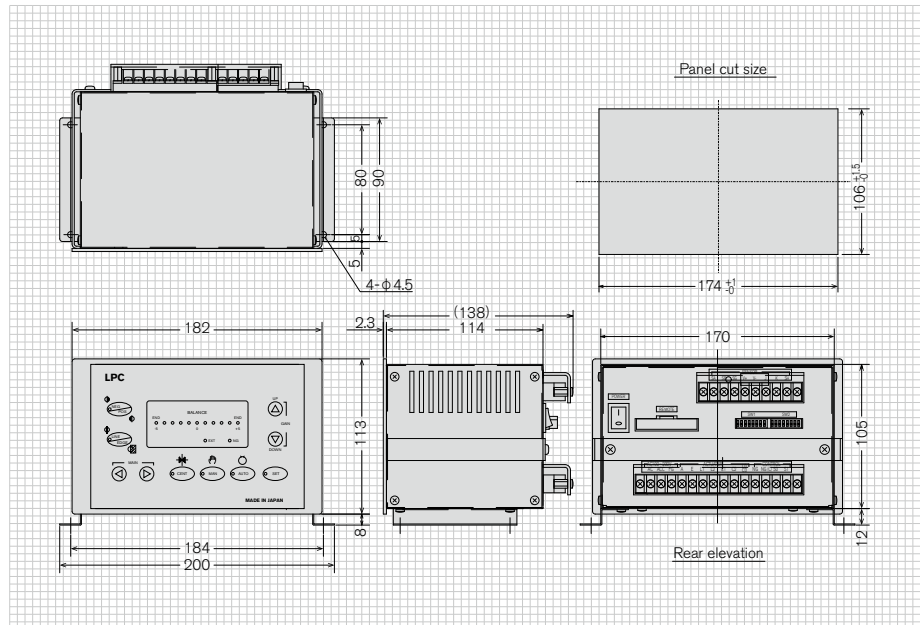

Front Operation Panel

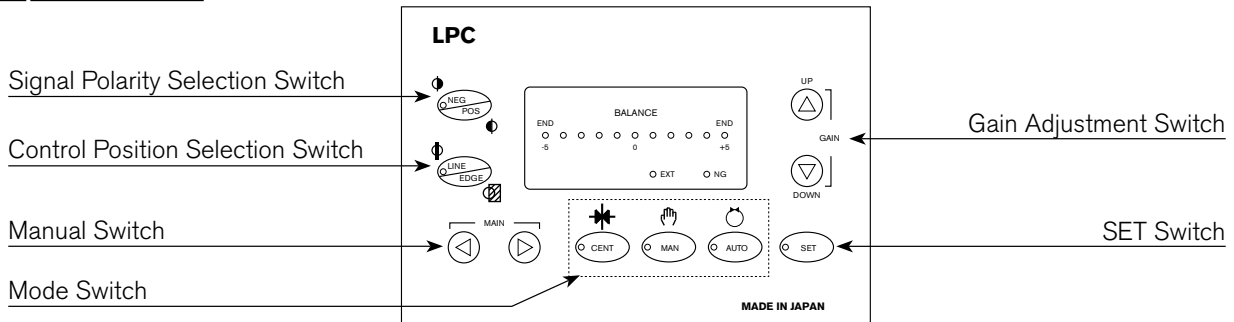

Specifications

	PW-800
Power Supply	Single Phase AC200V 50/60Hz
Power Consumption	Max. 80VA
Mass	Approx. 1.8kg
Environment	0~40°C (No condensation)
Sensor Input	Sensor Input Single Line

Fitting Sensor Table

Controller	Sensor
PW-800R	PS-261, PS-270, PS-1100
PW-800T	PS-711
PW-800U	PS-400, PS-45

3-3. PE-700

Feature

1. PE-700 Preamplifier can adjust the balance setting device by dial.
2. Sensing Status is shown on Analog Meter.

PE-700

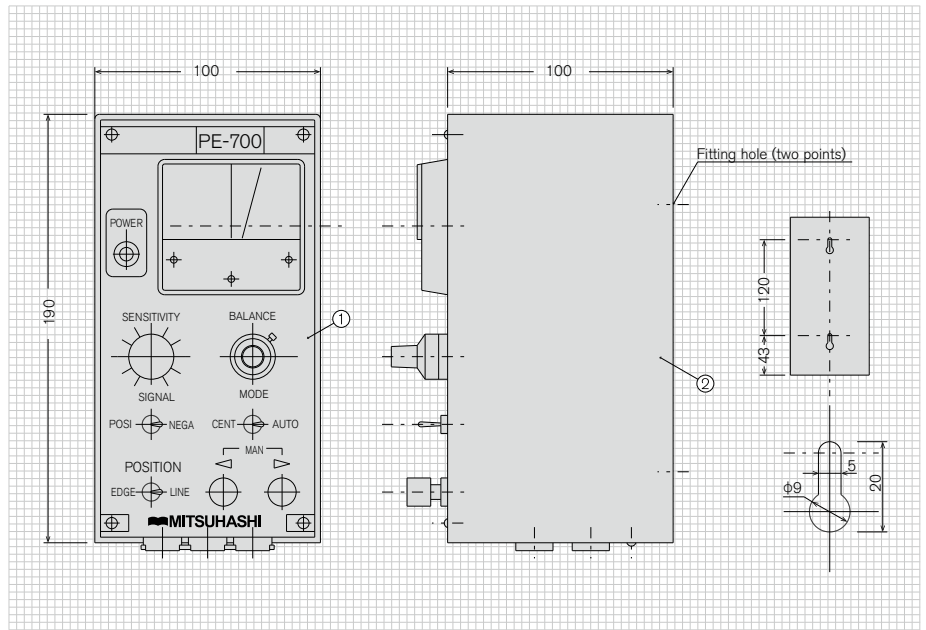
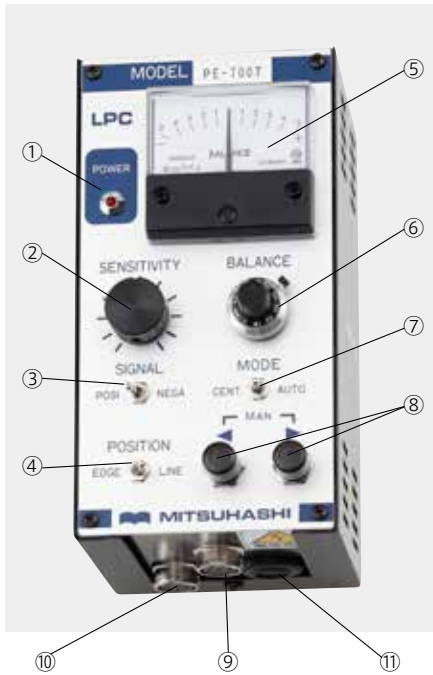

① PE-700 Body ② Case

- ① Power Indication Lamp
- ② Gain Adjustor
- ③ Polarity Selection Switch
- ④ Sensor Selection Switch
- ⑤ Balance Meter
- ⑥ Balance Adjustor
- ⑦ Operation Mode Selection Switch
- ⑧ Manual Operation Button
- ⑨ Operation Code Connector
- ⑩ Sensor Connector
- ⑪ Sensor Connector
(Only TC, C, and P type are attached)

Specifications

	PE-700
Control System	Input Proportional Contactless System
Power	DC ± 15V
Control Responsiveness	Electric Responsiveness Within 0.01sec
Input	Sensor, Driver
Output	DC ± 10V
Ambient Temperature	0°C -50°C
Mass	1kg

Fitting Sensor Table

Controller	Sensor
PE-700R	PS-261
PE-700T	PS-711
PE-700U	PS-400, PS-45
PE-700G	PS-800
PE-700C	PS-300, PS-350

3-4. PC-900/PC-930

General Description

● The PC-900 series driver has two operational modes.

Control mode by a motor ON-OFF input

The mode which carries out rate control in proportion to input voltage

● MF-6C of a filler lever type edge Sensor can be used. It combines with drive machines (Actuator, a control motor, etc.), and a meandering control system can be constituted.

● In processing machines, such as an unwinding machine, a winding machine, a heat setter and a tenter, coater, and a laminating machine, it is used for the meandering control on the basis of the edge position of a web.

Feature

1. The main circuit designed to drive a motor adopts a power transistor of thyristor (SCR), and the control circuit is composed of an operation amplifier and other semiconductor elements. Therefore, it involves no consumables, so it provides a longer service life and requires little or no maintenance.

2. Since the system incorporates a speed governor that can be used to set rotation speed in the clockwise (CW) and the counter-clockwise (CCW) directions in the ON-OFF operation mode, the speed can be achieved for a particular case.

3. If the limit switch included in the drive machine side operates, while a driver stops a motor, the object for limit switch operation check signals will be outputted by a relay contact. The control circuit of equipment and interlock can also be taken by this signal.

4. PC-900 series Drivers come in two types depending on driver capacity, PC-900 and PC-930, so a compact control system can be achieved.

5. PC-900 Driver can select wall-hanging or setting-up as mounting method by shifting the fitment, so it can be mounted at any location you desire.

PC-900

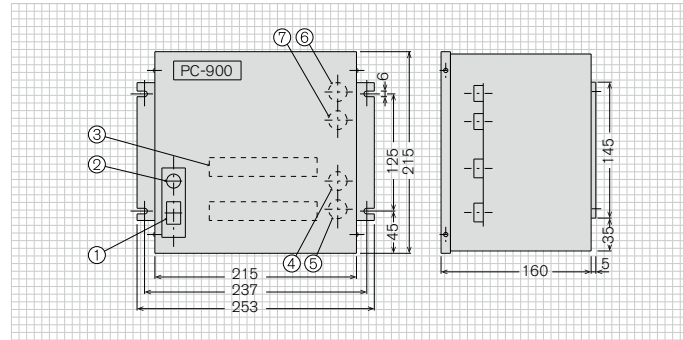

- ① Power Switch
- ② Power Lamp
- ③ External Connector
- ④ Sensor Connector
- ⑤ Operation Panel Connector
- ⑥ Fuse Power
- ⑦ Fuse Motor

PC-930

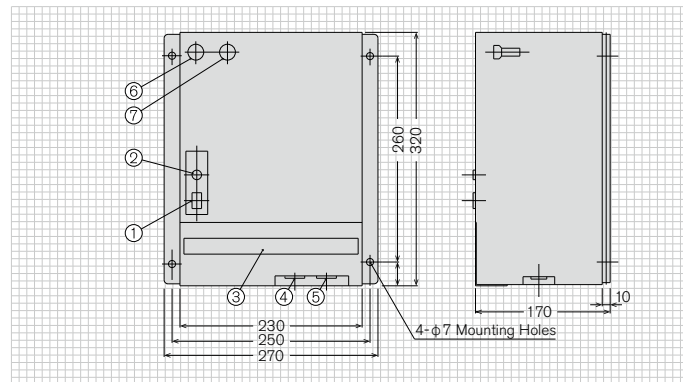

- ① Power Switch
- ② Power Lamp
- ③ External Connector
- ④ Sensor Connector
- ⑤ Operation Panel Connector
- ⑥ Fuse Power
- ⑦ Fuse Motor

Specifications

	PC-900	PC-930
Control System	DC Servo, Transistor Drive System	SCR Static Leonard System, Input Proportional Contactless System
Power	Single Phase AC200/220V 50/60Hz 1A	Single Phase AC200/220V 50/60Hz 3A
Control Responsiveness	Electric Responsiveness Within 0.01sec	Electric Responsiveness Within 0.01sec
Input	PE Type Preamplifier	PE Type Preamplifier
Output	DC24V 2A	DC24V 15A
Ambient Temperature	0~50°C	0~50°C
Alarm Contact	AC110V, 0.3A, DC24V, 1A (Resistance load)	AC110V, 0.3A, DC24V, 1A (Resistance load)
Mass	8kg	15kg

※ In detector PS-800 use, form is PC-900 E-PC-930E

4.Remote Interface Box

4-1. PT-1000

Outline

A PT-1000 type remote box can be used in combination with PW-1000, PW-2000, and a PW-1310 type controller.

Mode Switch

Select the operation mode

CENT (Center)

Moves the actuator to the center

MAN (Manual)

Drives the actuator by manual operation

AUTO (Automatic)

A sensor detects the position of a web and the gap is corrected automatically.

PT-1000



Control Position Selection Key

LINE or EDGE Selection Key
The lamp is lighting at the time of LINE selection.

Single Polarity Selection Key

NEG/POS Selection Key
The lamp is lighting at the time of NEG selection.

SET Key

Automatic Balance Set Key
The lamp is lighting at the time of the completion of a set.

Manual Operation Key

During MAN mode, operation is possible
It is zero during AUTO mode
Finely Adjustable

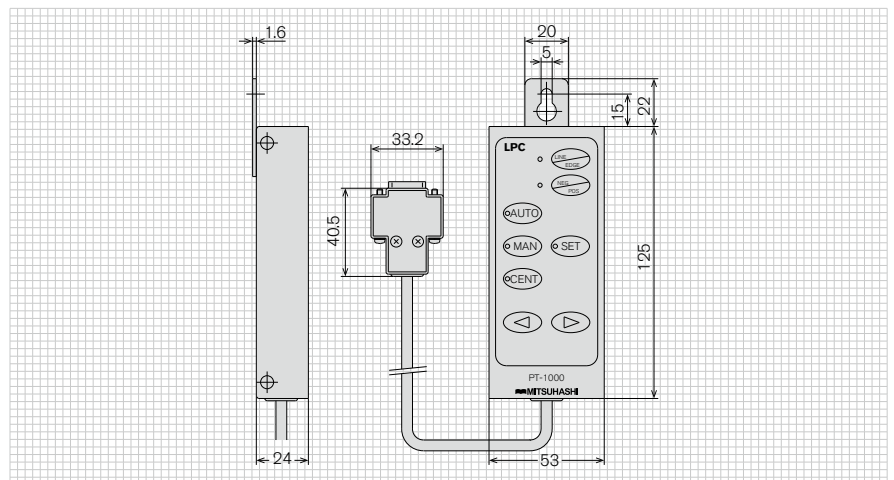

4-2. PT-800



Outline

A PT-800 type remote box can be used in combination with a PW-800 type controller.

PT-800

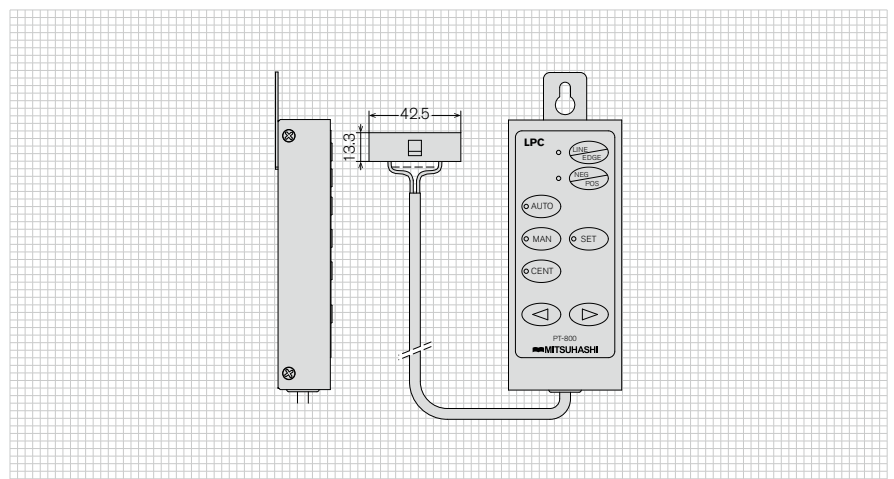



Lending “hands” to replace
human hands.

株式会社 三橋製作所
MITSUHASHI CORPORATION

Head Office

Postal Code 615-0082 1, Sekizan-cho, Yamanouchi,
Ukyo-ku, Kyoto, JAPAN
TEL 81-75-316-3300 (the sales department)
FAX 81-75-313-7595

Tokyo Branch (Export Office)

Postal Code 111-0043 YoshikuniKomagata-bldg.9F,
2-4-11, Komagata, Taitou-ku, Tokyo, JAPAN
TEL 81-3-3847-9751
FAX 81-3-3847-9753

Kyushu Branch

Postal Code 812-0016 Minamikindai-bldg.6F,
4-2-10, Hakataekiminami, Hakata-ku, Fukuoka, JAPAN
TEL 81-92-476-3800
FAX 81-92-476-3801

Shanghai Mitsuhashi trading company

Room 1314, 36 Lanes, 1200 chang qing Road, Shanghai, CHINA
TEL & FAX 86-21-5068-5366

In order to improve our products, specifications may change without notice