

MRV-8 Anti-Wrinkle Roller

*The compact MRV
for small webs*



Feature

It is an Anti-Wrinkle Roller for small webs (the maximum web width of 650 mm). A roll outer diameter is ϕ 85 mm of the series minimum, and can be attached compactly.

Standard specification

Roll outer diameter	phi85mm
Roll length	A maximum 700 mm (25-mm knurl)
The maximum contact angle	Right angle
The maximum sheet speed	100m/min
The maximum tension	100N
Operating temperature range	0 ~ 80°C
Rubber quality of material	NBR (white/black), EPT (white/black)

Notes: The manufacture about the specification besides a standard is also accepted.

【 About a wrinkles picking effect 】

This product spread the web twisted around the perimeter by the growth of rubber. For this reason, it changes with the quality of the material (slide nature, elasticity, hardness) of a web, a size (width, thickness) and the installation requirements (arranging and twisting angle) of a roll, the environment (temperature, humidity), machine specification (line speed, sheet tension), and etc. For details, please consult.

Outline drawing

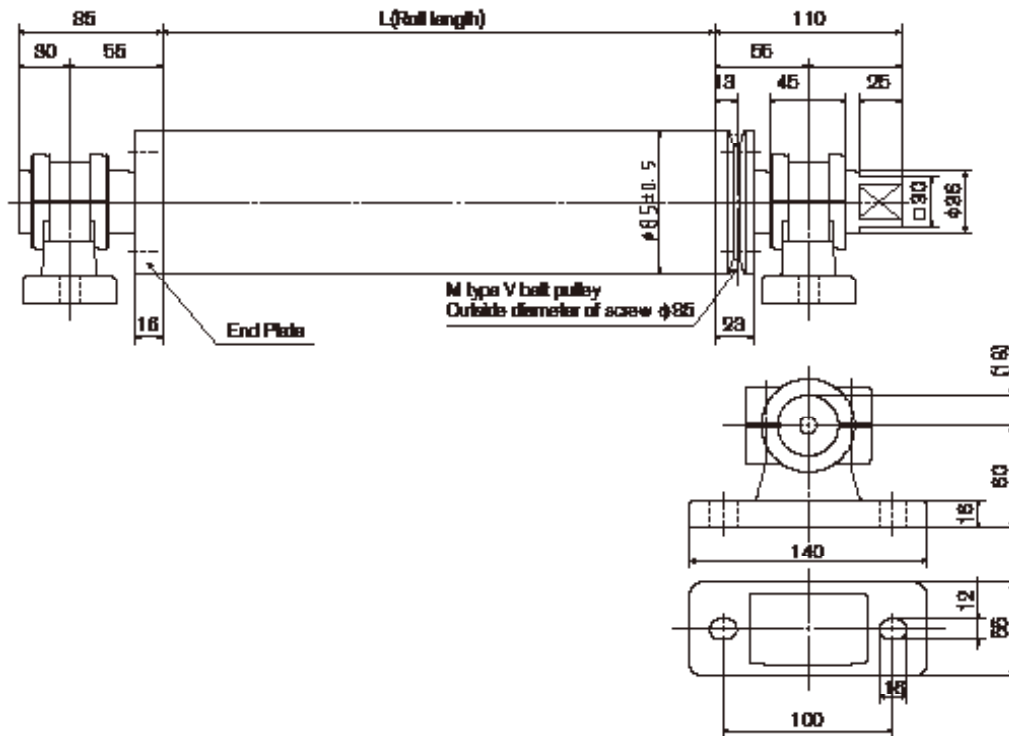

Lending “hands” to replace human hands.

www.mitsubishi-corp.co.jp

株式会社 三橋製作所 MITSUHASHI CORPORATION

- Head Office/
Factory
 1 Sekizan-cho Yamanouchi Ukyo-ku Kyoto
615-0082 Japan
TEL:+81-75-316-3300 FAX:+81-75-313-7595
- Tokyo Office/
Overseas Sales Division
 Yoshikuni Komagata Bldg. 9F 2-4-11 Komagata
Taitoh-ku Tokyo 111-0043 Japan
TEL:+81-3-3847-9751 FAX:+81-3-3847-9753
- Kyushu Office
 Minamikindai Building 6F, 4-2-10 Hakataekiminami
Hakata-ku Fukuoka 812-0016 Japan
TEL:+81-92-476-3800 FAX:+81-92-476-3801