



KD-820 / KK-350 POUCH DISPENSER

*Accurate
Dispensing,
Following
Line Speed*



Features

- **Automatically** follows packing machine line speed
 - Dispensing accuracy is maintained regardless of packing machine line speed changes.
- **Easy** maintenance
 - Accurate dispensing unit (KK-350) is controlled by KD itself. No PCB for KK-350.
 - KK-350 unit is easily dismantled for daily cleaning & maintenance.
- **Easy adjustments at line layout changes**
 - KK-350 controlled by KD enables various setting changes by operation panel

Basic Specs

Capacity	Max. 200 sachets / minute (at sachet length of 70mm or less)
Sachet Specification	Width: 20 – 100mm Length: 30 – 150mm Thickness: 7mm
Equipment Dimension	360mm (W) × 130mm (H) × 338mm (D)
Power	AC200/220V, 50/60Hz, 3 Phase, 1.5kVA (with KD-820)
Weight	Approx. 15kg (approx. 45kg with KD-820)

Overview

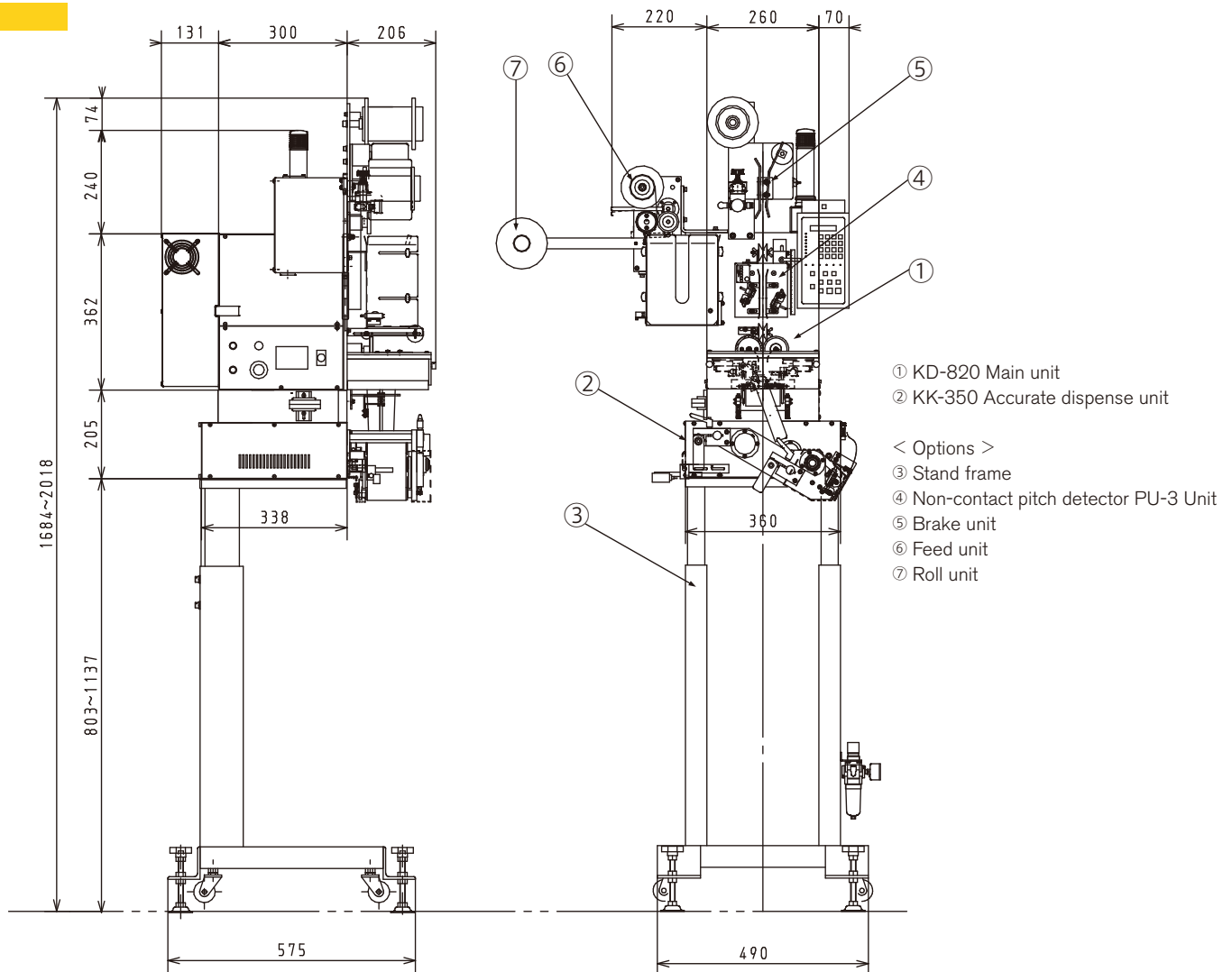

Lending “hands” to replace human hands.

www.mitsubishi-corp.co.jp

株式会社 三橋製作所

MITSUHASHI CORPORATION

□ Head Office/
Factory

1 Sekizan-cho Yamanouchi Ukyo-ku Kyoto
615-0082 Japan
TEL:+81-75-316-3300 FAX:+81-75-313-7595

□ Tokyo Office/
Overseas Sales Division

Yoshikuni Komagata Bldg. 9F 2-4-11 Komagata
Taitoh-ku Tokyo 111-0043 Japan
TEL:+81-3-3847-9751 FAX:+81-3-3847-9753

□ Kyushu Office

Minamikindai Building 6F, 4-2-10 Hakataekiminami
Hakata-ku Fukuoka 812-0016 Japan
TEL:+81-92-476-3800 FAX:+81-92-476-3801