

KD-820 POUCH DISPENSER

**COMPACT
BODY
DUAL
BLADE
Drive**

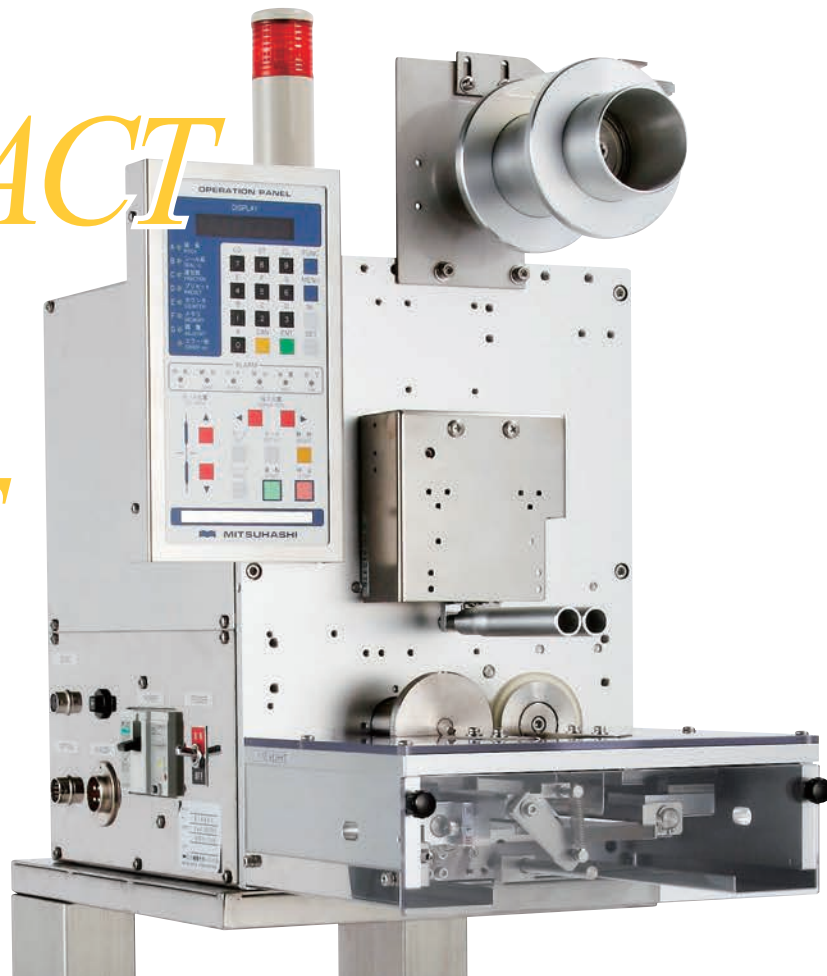

Features

- Maximum process capacity 300 sachets / minute
- Dual drive blade enables to cut sachets up to 30mm in thickness
- AC servo motor drive cutter unit
- Cutter angle adjustment function prevents diagonal cuts
- Removal cutter units
- 32 bit microcomputer controlled
- Various options

Options

- Non-contact pitch measurement unit : Sachet seal area detected without direct contact
- Feed unit : Applied to heavier sachets to assist specified feeding length
- Vibrator : Applied to powder sachets to ensure accurate thickness detection
- Liquid unit : Applied to liquid sachets to ensure accurate thickness detection
- Stand frame : 803 – 1121mm adjustable



KD-820

Basic Specs

Capacity	Max. 300 sachets / minute (at sachet length of 50mm) * Capacity to decrease as sachet length becomes longer * Capacity is subject to change based on various conditions
Sachet Specification	Max. 100mm (W) x 150mm (L) x 30mm (T)
Equipment Dimension	Main unit 260mm (W) x 362mm (H) x 506mm (D)
Cutting Accuracy	$\cong \pm 1.5\text{mm}$
Power	AC200/220V, 50/60Hz, 3 Phase, 1.5kVA
Weight	Main unit 30kg
Cutter Drive	AC servo motor

Overview

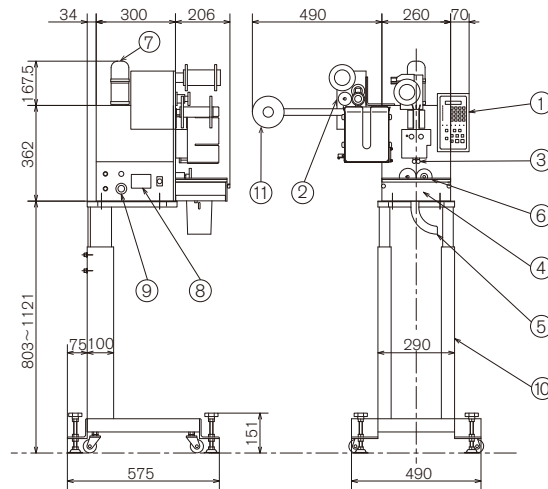

- ① Control box
- ② Feed unit (Option)
- ③ Thickness detection roller
- ④ Cutter unit
- ⑤ Chute
- ⑥ Pitch feed unit
- ⑦ Lamp
- ⑧ Power switch
- ⑨ Connector
- ⑩ Stand frame (option)
- ⑪ Roll unit - A

Apparatuses

Vacuum Suction Unit



Accurate placing

- High speed 200pcs/min.
- Silent & accurate placing
- Suitable for right angle dispensing to the packing machine
- Sachet cutting & sticking is possible by combining with our TM-200 taping machine

Stitch-Line / I-Notch Dispense Conveyor



High speed cutting with stitch-line

- Processes stitch-lined double & triple pouches
- High speed 200pcs/min.
- Dispense conveyor for secure placing of sachets
- Air cylinder notching unit

Model KK-350 Accurate Dispenser



Accurate dispense at line speed

- Speed synchronized to packing machine
- Easy dismantable belt unit

Application Examples

< Object products >

Desiccant	Cofectonery/ seaweed/ delicacies/ food in general	V.F.F.S Packaging machine
Soup/ spice	Instant noodle	H.F.F.S Packaging machine
Syrup	Cofectonery	
Sauce/ mustard	Food in general	Cartoning machine
Spoon/ Fork		

Configurations

Connected to the H.F.F.S Packaging machine

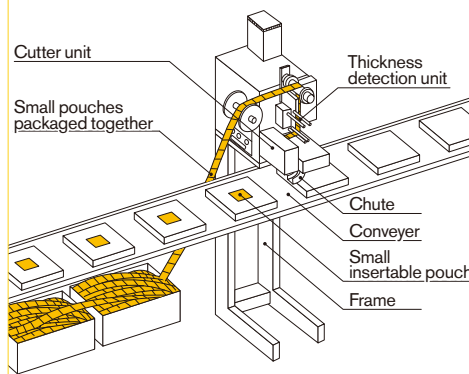

Connected to the V.F.F.S Packaging machine

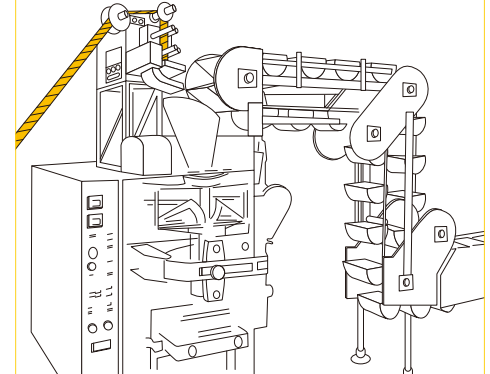

Lending “hands” to replace human hands.

www.mitsubishi-corp.co.jp

株式会社 三橋製作所

MITSUHASHI CORPORATION

□ Head Office/
Factory

1 Sekizan-cho Yamanouchi Ukyo-ku Kyoto
615-0082 Japan
TEL:+81-75-316-3300 FAX:+81-75-313-7595

□ Tokyo Office/
Overseas Sales Division

Yoshikuni Komagata Bldg. 9F 2-4-11 Komagata
Taitoh-ku Tokyo 111-0043 Japan
TEL:+81-3-3847-9751 FAX:+81-3-3847-9753

□ Kyushu Office

Minamikindai Building 6F, 4-2-10 Hakataekiminami
Hakata-ku Fukuoka 812-0016 Japan
TEL:+81-92-476-3800 FAX:+81-92-476-3801