

CS-300 Automatic Pouch Stocker



*More
User-friendly
with Touch
Screen!*

Features

- Pouches are counted, aligned, and packed in boxes.
- Easy-to-use 10-inch color touch screen.
- Improved machine design and increased durability.
- Easy switching sachets types. Up to 50 types are able to register.

Specifications

Capabilities	240 sachets/min (max.) Sachet Length 50mm, Capacity is 12m/min approx.
Pouches Specifications	Width 65–150mm
	Length 480mm (Continuous Sachets Length)
	Thickness 10mm (max.)
Box dimensions	Length 500mm (max.)
	Width 450mm (max.)
	Height 290mm (max.)
Box Weight	Max. 15kg
Power	3 φ AC200V 50/60Hz 1.0kVA
Machine weight	(Main Unit) Approx. 100kg
Air supply	0.5MPa 20 ℓ/min (ANR) dry air

※ Equipment capacity depends on the requested specifications.

Drawing

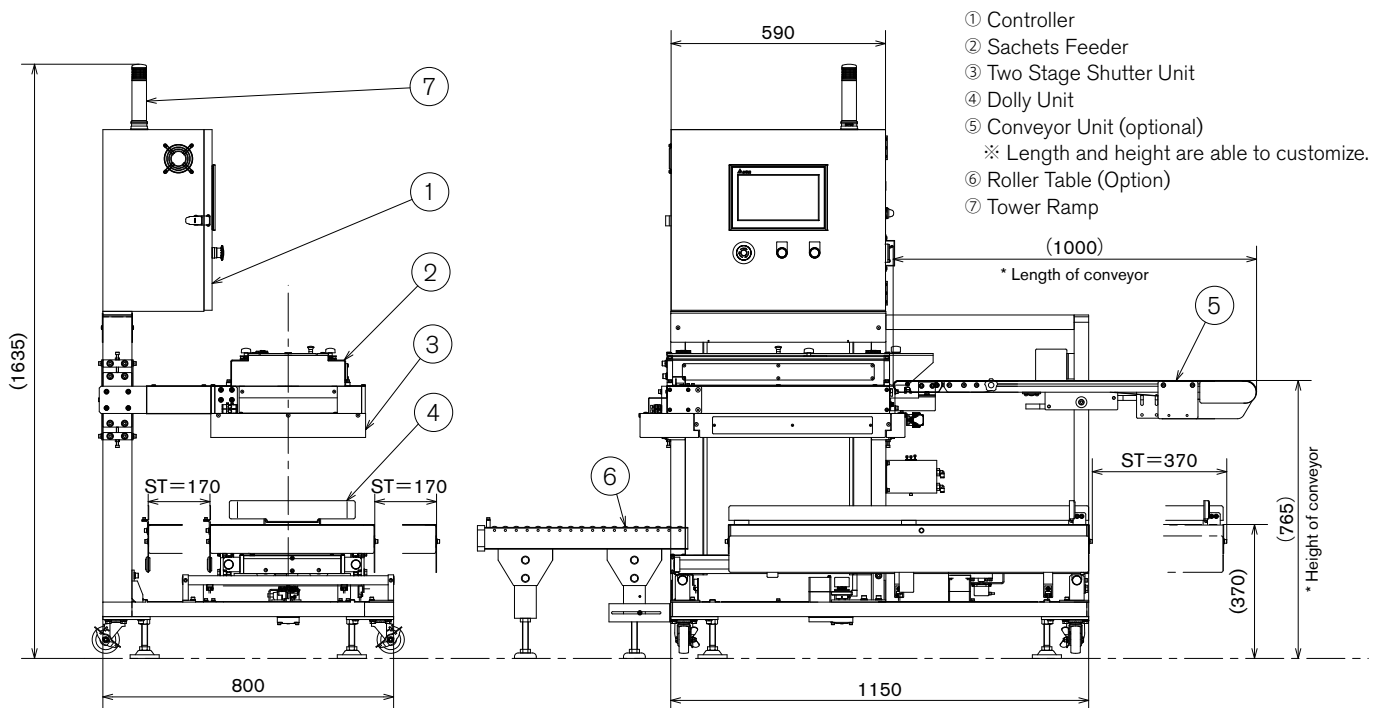

株式会社 三橋製作所 MITSUHASHI CORPORATION



Lending “hands” to replace human hands.

<https://www.mitsuhashi-corp.co.jp>

- Head Office/
Factory
 1 Sekizan-cho Yamanouchi Ukyo-ku Kyoto
615-0082 Japan
TEL:+81-75-316-3300 FAX:+81-75-313-7595
- Tokyo Office/
Overseas Sales Division
 Yoshikuni Komagata Bldg. 9F 2-4-11 Komagata
Taitoh-ku Tokyo 111-0043 Japan
TEL:+81-3-3847-9751 FAX:+81-3-3847-9753
- Kyushu Office
 Minamikindai Building 6F, 4-2-10 Hakataekiminami
Hakata-ku Fukuoka 812-0016 Japan
TEL:+81-92-476-3800 FAX:+81-92-476-3801