

Folding quirk modification device

RC-100

*Instantly
modify
folding
quirk*



Feature

- Instantly modify folding quirk by using panel heater.
- Machine life is longer when compare to our conventional machine.
- Corresponding to various supply method (ceiling supply, floor supply, etc.)
- Can run in associate with our cutting machine or also available to existing equipment.

Specification

Pouch specification	Pouch material : aluminum, PP, etc... Content : powder, liquid Width : ~ 150mm Thickness : ~ 15mm
Power	1 φ AC200V/220V 50/60Hz 2kVA
Weight	Approx. 18 kg

Overview

Ceiling supply method

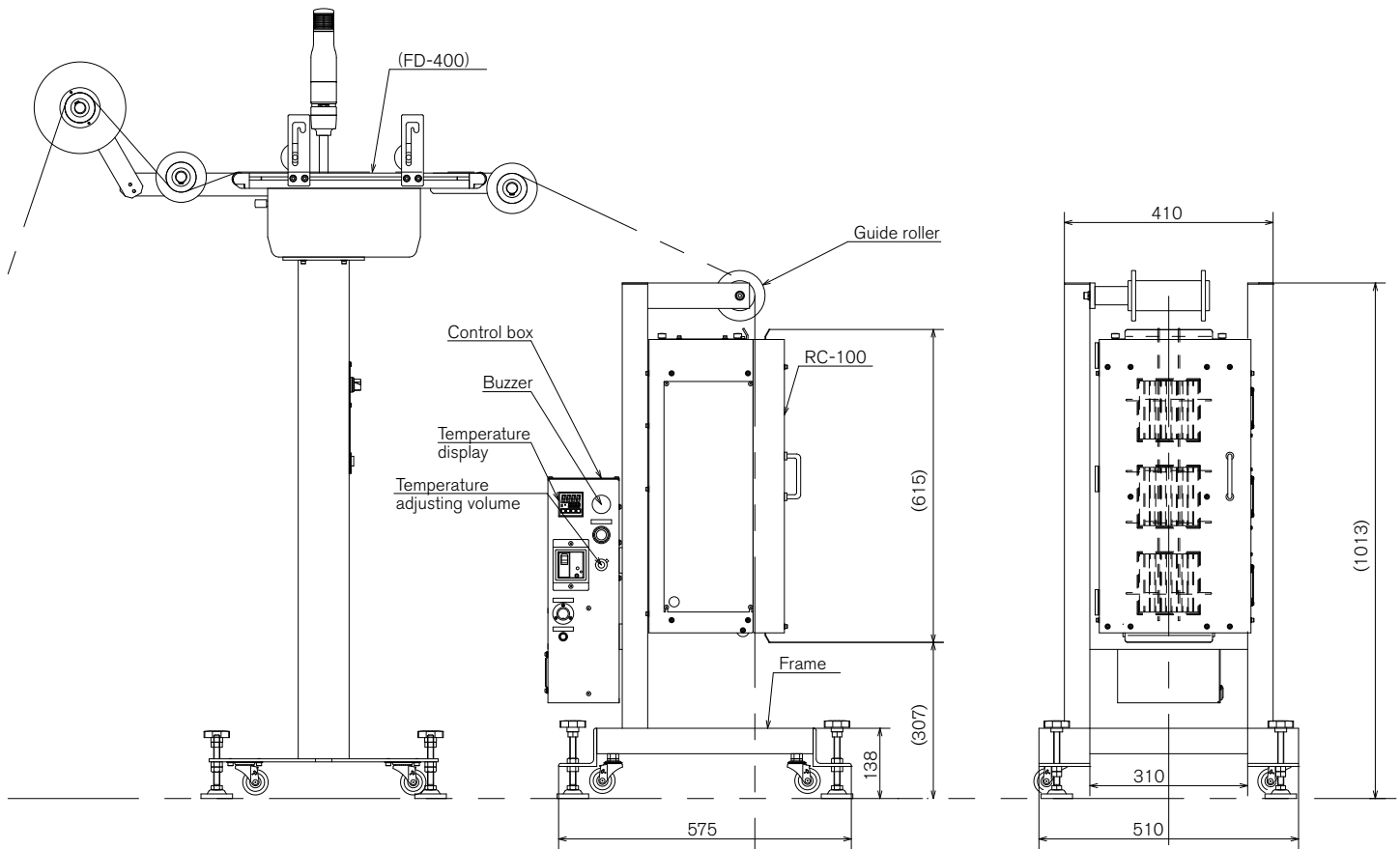

株式会社 三橋製作所 MITSUHASHI CORPORATION



www.mitsubishi-corp.co.jp
info@mitsubishi-corp.co.jp

- Head Office/
Factory

1 Sekizan-cho Yamanouchi Ukyo-ku Kyoto
615-0082 Japan
TEL:+81-75-316-3300 FAX:+81-75-313-7595
- Tokyo Office/
Overseas Sales Division

Yoshikuni Komagata Bldg. 9F 2-4-11 Komagata
Taitoh-ku Tokyo 111-0043 Japan
TEL:+81-3-3847-9751 FAX:+81-3-3847-9753
- Kyushu Office

Minamikindai Building 6F, 4-2-10 Hakataekiminami
Hakata-ku Fukuoka 812-0016 Japan
TEL:+81-92-476-3800 FAX:+81-92-476-3801