

# KD-820 / LV-1000 POUCH DISPENSER

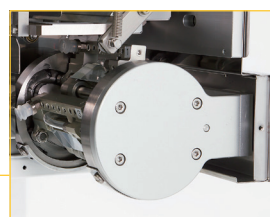

*HIGH  
ACCURACY  
DISPENSING*



Equipped with Rotary Vacuum Suction Unit LV-1000

## Features

- Consecutive rotary movement for high speed dispensing at 250pcs/minute
- Automatically follows packing machine line speed (encoder unit required), preventing sachet misplacement. ( Position deviation significantly reduce when compare with LV-200)
- Simultaneous clinching, suctioning & cutting actions prevents mis-cutting of folded and/or curled sachets

## Basic Specs

KD-820 Main unit + LV-1000

Capacity	Max. 250 sachets / minute (at sachet length of 50mm) * Capacity to decrease as sachet length becomes longer * Capacity is subject to change based on various conditions
Sachet Specification	Width: 30 – 100mm Length: 35 – 90mm *Note Thickness: 1 – 10mm
Equipment Dimension	634mm (W) × 812mm (H) × 755mm (D)
Power	AC200/220V, 50/60Hz, 3 Phase, 1.5kVA
Weight	Approx. 50kg (KD-820 + LV-1000), approx. 37kg (Vacuum pump)
Air utility	0.5MPa 80 ℓ /min. (ANR)

\* Note: Option jack unit is required for sachets exceed length of 70mm

\* Note: It may be difficultly adsorbed by the pouch form. Please contact us for more information.

\* Note: This products is custom made.

## Overview

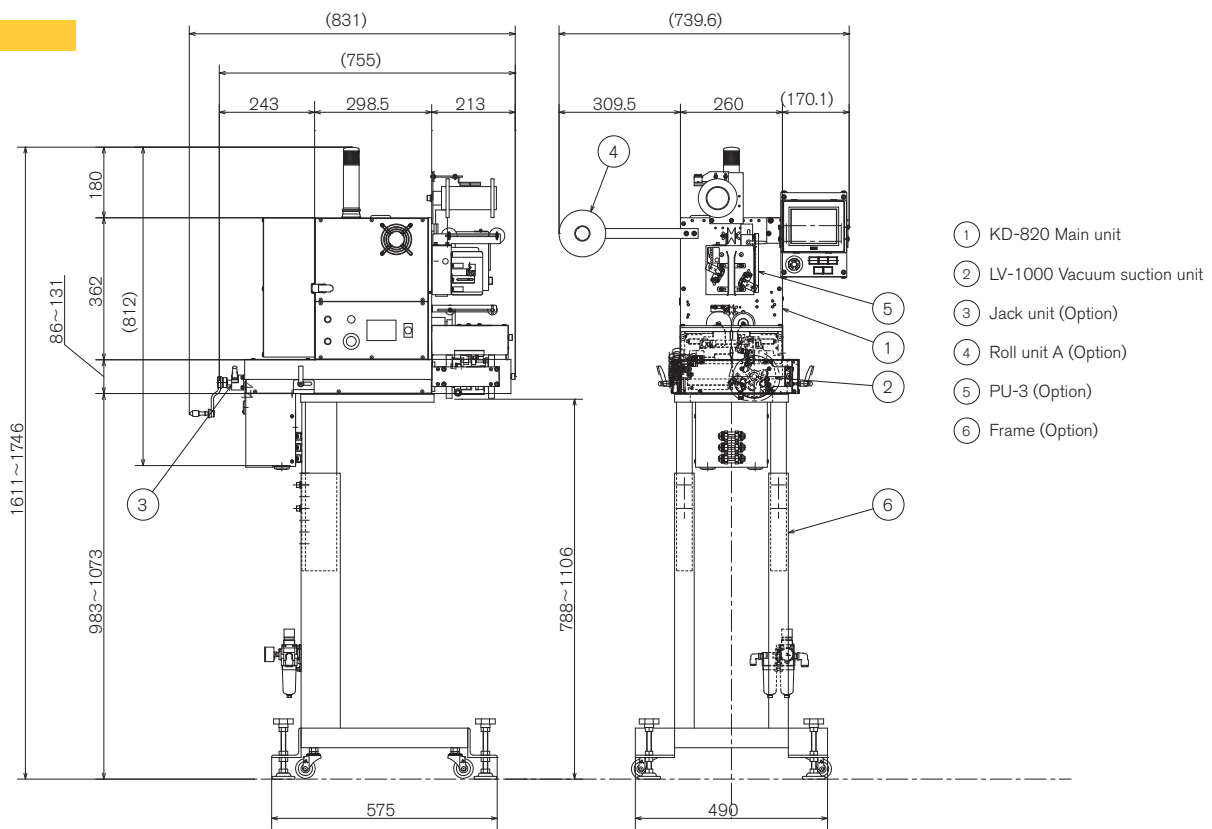

\* Drawing shows model LV-1000R. Symmetrical model is LV-1000L.

Please understand that we may change the specification without notice for product improvement.



[www.mitsubishi-corp.co.jp](http://www.mitsubishi-corp.co.jp)  
[info@mitsubishi-corp.co.jp](mailto:info@mitsubishi-corp.co.jp)

株式会社 三橋製作所

**MITSUHASHI CORPORATION**

□ Head Office/  
Factory

1 Sekizan-cho Yamanouchi Ukyo-ku Kyoto  
615-0082 Japan  
TEL:+81-75-316-3300 FAX:+81-75-313-7595

□ Tokyo Office/  
Overseas Sales Division

Yoshikuni Komagata Bldg. 9F 2-4-11 Komagata  
Taitoh-ku Tokyo 111-0043 Japan  
TEL:+81-3-3847-9751 FAX:+81-3-3847-9753

□ Kyushu Office

Minamikindai Building 6F, 4-2-10 Hakataekiminami  
Hakata-ku Fukuoka 812-0016 Japan  
TEL:+81-92-476-3800 FAX:+81-92-476-3801