

CD-870 CARD DISPENSER



Features

- Designed to pick & dispense cardboards, trays, lids and flat sachets
- Work material stocked by conveyor, capable of large stocks
- Patent registered cam-rack adopted for drive mechanism achieved compact & smooth movement
- Automatic dispensing at synchronized line speed by receiving signals from equipments such as packing machine
- Equipped with AC servo motor drive

Basic Specs

Capacity	Max. 120 pcs / minute
Work Material Size	Width: 20 – 200mm Length: 30 – 200mm
Power	AC200/220V, 50/60Hz, 3 Phase, 1kVA
Air Utility	0.5MPa 110 ℓ /min. (ANR) * Dry air
Equipment Dimension	423mm (W) x 161mm (H) x 210mm (D) * Notes
Weight	Approx. 50kg (based on below overview drawing)

* Note 1: CD-870 main unit dimension (excluding feed conveyor, base stand, safety cover)

* Note 2: Feed conveyor, base stand, safety cover are to be designed according to work material size(s) and stock volume.

Overview

Referential drawing at feed conveyor length 600mm

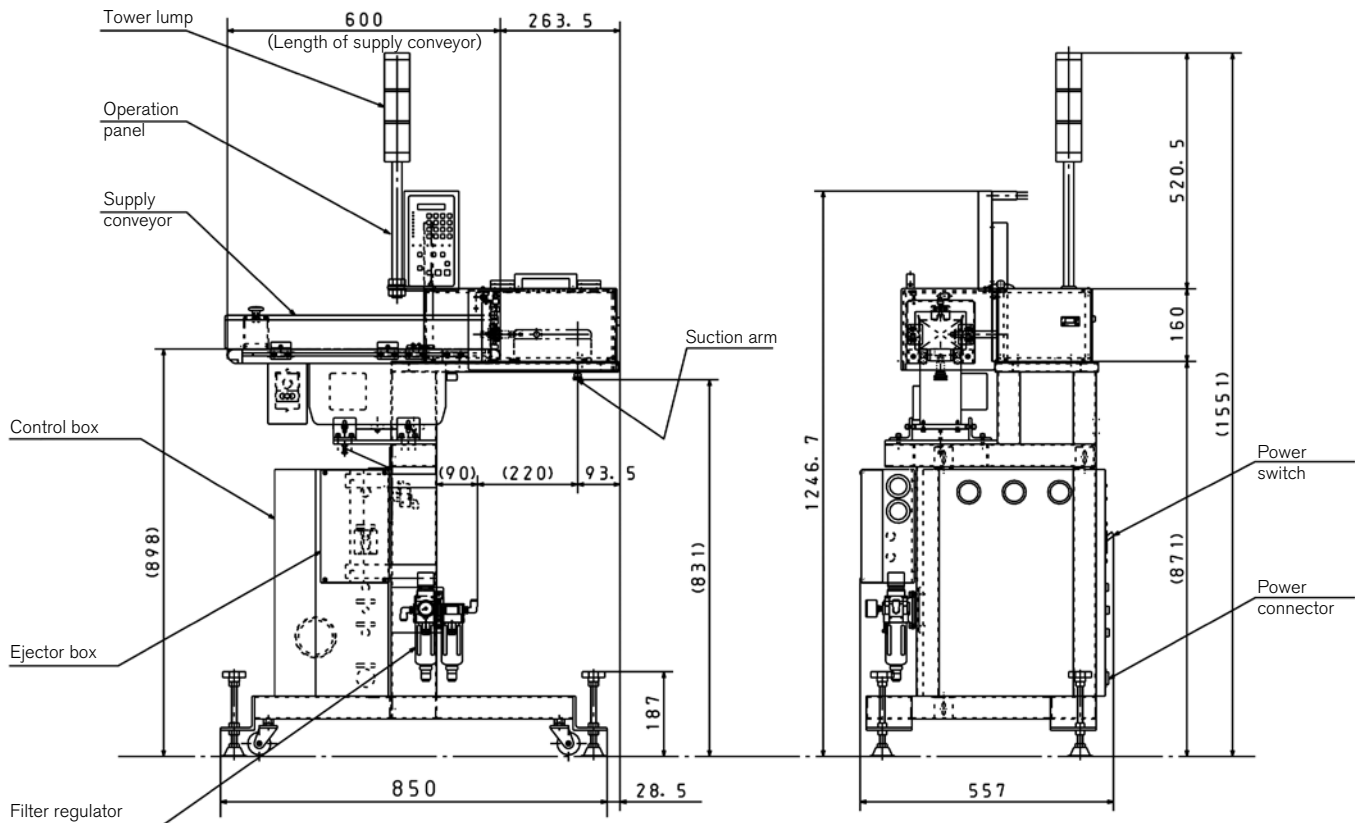

www.mitsubishi-corp.co.jp
info@mitsubishi-corp.co.jp

株式会社 三橋製作所

MITSUHASHI CORPORATION

□ Head Office/
Factory

1 Sekizan-cho Yamanouchi Ukyo-ku Kyoto
615-0082 Japan
TEL:+81-75-316-3300 FAX:+81-75-313-7595

□ Tokyo Office/
Overseas Sales Division

Yoshikuni Komagata Bldg. 9F 2-4-11 Komagata
Taitoh-ku Tokyo 111-0043 Japan
TEL:+81-3-3847-9751 FAX:+81-3-3847-9753

□ Kyushu Office

Minamikindai Building 6F, 4-2-10 Hakataekiminami
Hakata-ku Fukuoka 812-0016 Japan
TEL:+81-92-476-3800 FAX:+81-92-476-3801