

KD-920 POUCH DISPENSER

LOW
COST
Model



Features

- Solenoid driven single blade unit adopted for cost reduction
- High performance 32bit micro-computer control
- Wide variety of options;
 - Feed unit for heavier sachet dispensing
 - Vibrator unit for stable pitch detection of fine powder sachets, etc.

Basic Specs

Dispensing Capacity	Max. 200 sachets / minute *At sachet pitch 70mm
Sachet Size	Width: 20 – 100mm Length: 30 – 150mm Thickness: Max. 10mm
Equipment Dimension	W320 x H420 x D500mm *Main body
Cutting Accuracy	$\geq \pm 1.5\text{mm}$
Power	AC200V 50/60Hz Single phase 0.5kVA
Weight	Approx. 45kg (with feed unit: approx. 53kg) *Main body

Overview

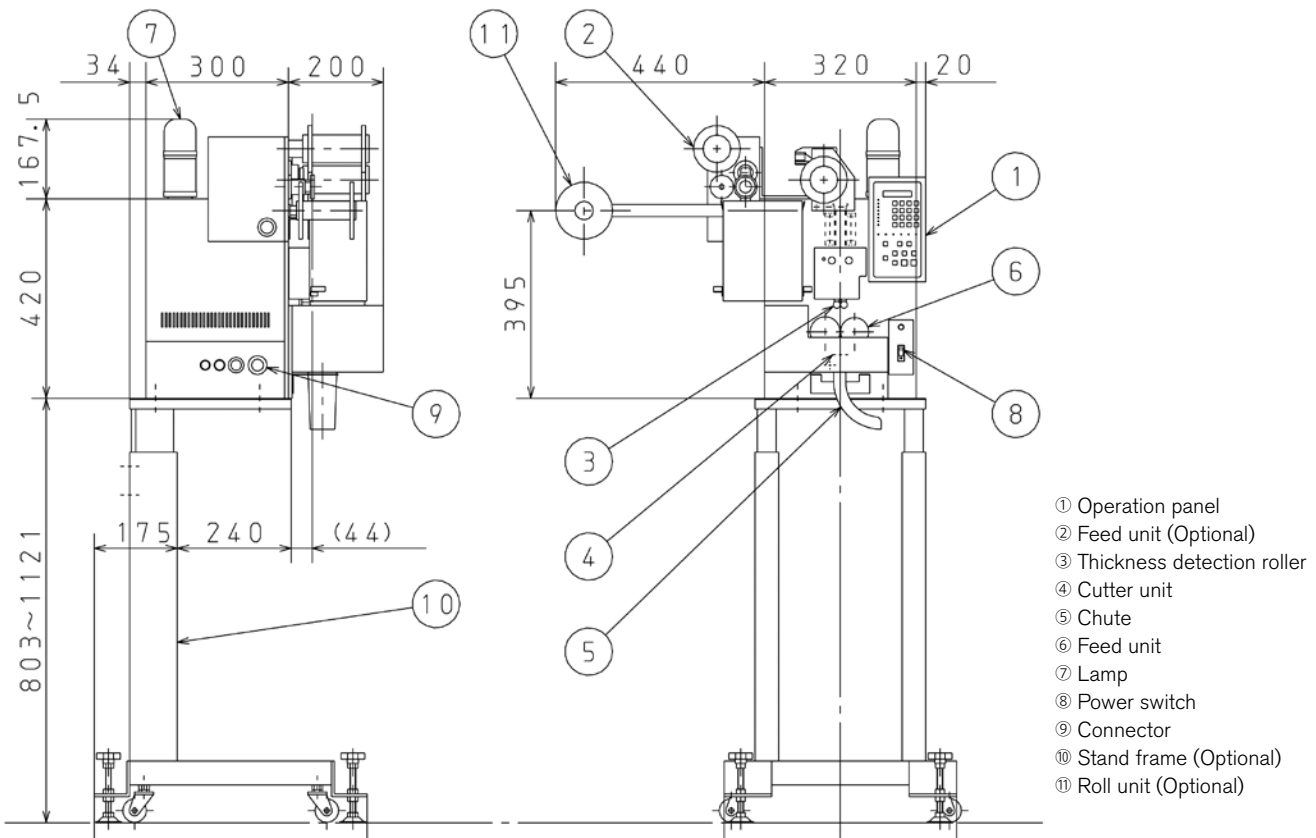

www.mitsubishi-corp.co.jp
info@mitsubishi-corp.co.jp

株式会社 三橋製作所

MITSUHASHI CORPORATION

□ Head Office/
Factory

1 Sekizan-cho Yamanouchi Ukyo-ku Kyoto
615-0082 Japan
TEL:+81-75-316-3300 FAX:+81-75-313-7595

□ Tokyo Office/
Overseas Sales Division

Yoshikuni Komagata Bldg. 9F 2-4-11 Komagata
Taitoh-ku Tokyo 111-0043 Japan
TEL:+81-3-3847-9751 FAX:+81-3-3847-9753

□ Kyushu Office

Minamikindai Building 6F, 4-2-10 Hakataekiminami
Hakata-ku Fukuoka 812-0016 Japan
TEL:+81-92-476-3800 FAX:+81-92-476-3801