

TM-200 TAPING MACHINE



*Easy Adjustment,
Easy Operation,
Double-Sided Tape
Pasting Machine*

KD-820 & LV-100(L)

Photo: Configuration example of TM-200 adopted with KD-820 & LV-100 (L)

Features

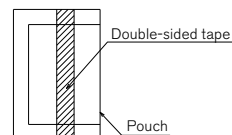

Pasting example

- Designed to paste double-sided tape strips onto chain sachets
- Compared to the previous TM-120, adjustments are possible without using tools
- Reset switch, error display LED newly added. Operation switch is modified to light type for clearer view
- Configuration with our Pouch Dispenser enables tape pasting onto cut sachets at Packing line speed
- Pasting of sachets onto trays or wrapping film prevents direct contact with the food
- Selection of pasting from chute pasting, stamping or vacuum pick & pasting

Basic Specs

Capacity	50Hz: Max. 6.2m/minute 60Hz: Max. 7.4m/minute
Pouch Specification	Width: 20 - 60mm Length: 30 - 150mm Thickness: less than 5mm Maximum roll diameter: 300mm Maximum reel width: 255mm
Power	AC200V, 50/60Hz, Single Phase, 200VA (Supplied from Pouch Dispenser)
Weight	Approx. 55kg

Overview

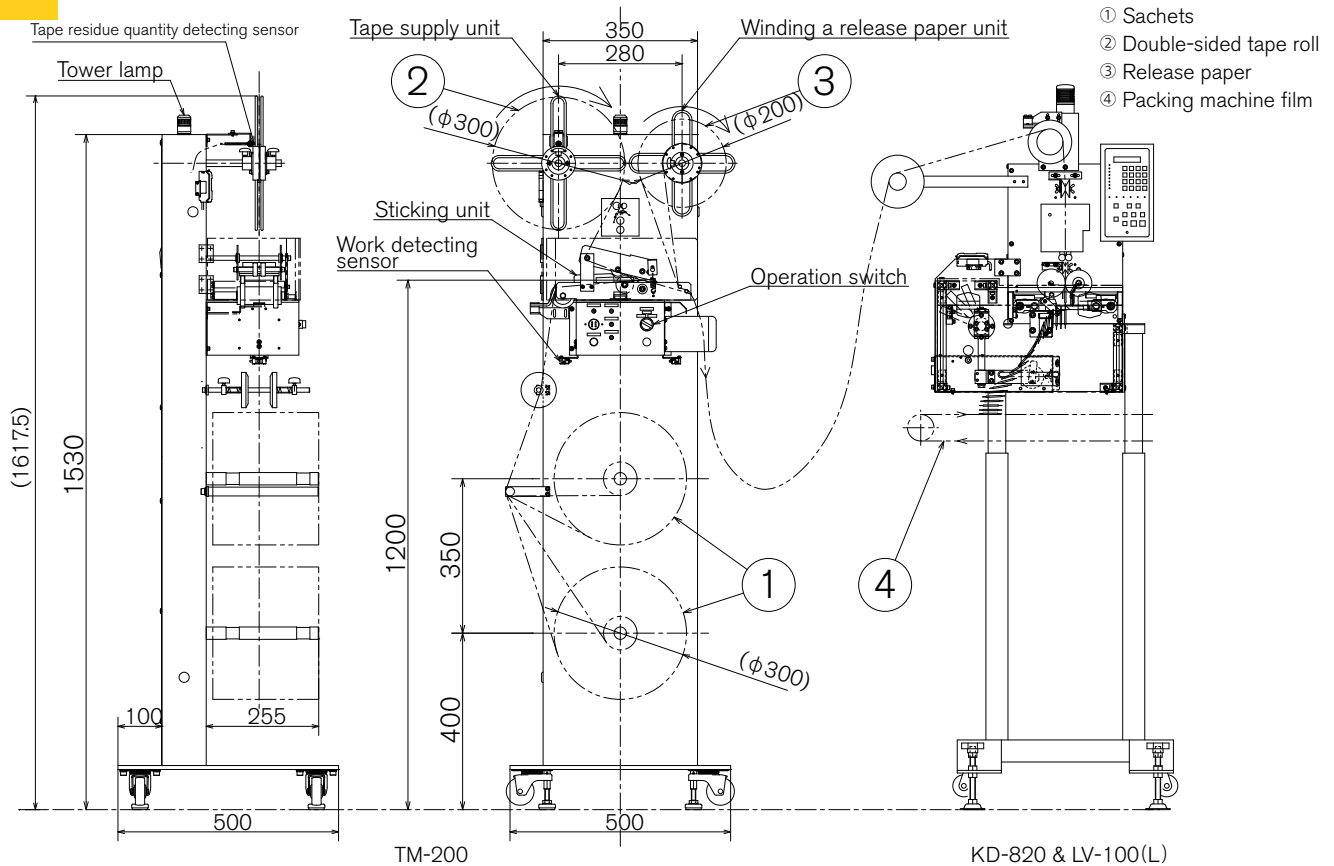

株式会社 三橋製作所

MITSUHASHI CORPORATION



www.mitsubishi-corp.co.jp
info@mitsubishi-corp.co.jp

□ Head Office/
Factory

1 Sekizan-cho Yamanouchi Ukyo-ku Kyoto
615-0082 Japan
TEL:+81-75-316-3300 FAX:+81-75-313-7595

□ Tokyo Office/
Overseas Sales Division

Yoshikuni Komagata Bldg. 9F 2-4-11 Komagata
Taitoh-ku Tokyo 111-0043 Japan
TEL:+81-3-3847-9751 FAX:+81-3-3847-9753

□ Kyushu Office

Minamikindai Building 6F, 4-2-10 Hakataekiminami
Hakata-ku Fukuoka 812-0016 Japan
TEL:+81-92-476-3800 FAX:+81-92-476-3801