

# CS-150W POUCH STOCKER

*ACCURATE  
COUNTING!  
UNIFORMED  
CASING!*



## Features

- High speed casing at **240pcs / minute**
- Width adjustable rotary shutter
  - ⇒ **applicable work material size 65 – 150mm**
- **AC servo driven** rotary shutter
  - ⇒ high speed, but quiet working environment
- **Emboss plate** adopted for shutter unit
  - ⇒ long chain sachets are straightly cased
- **Twin shutter structure**
  - ⇒ Sachets are continuously provided & counted without temporary stop during case changing

## Basic Specs

Capacity	240 pcs / minute (Single sachet, 100mm pitch) 120 pcs / minute (2 pcs chain sachet, 100mm pitch)
Work Material Size	Sachet length: 70 – 130mm Sachet width: 65 – 150mm Maximum chain length: 500mm
Case Dimension	Length: 400 – 550mm Width: Max. 450mm Height: Max. 290mm
Casing Weight	Max. 15kg
Power	AC200/220V, 50/60Hz, 3 Phase
Air Utility	0.5MPa 20 ℓ /min. (ANR)
Weight	Approx. 100kg
Color	Munsell N-9.5 (White)

## Overview

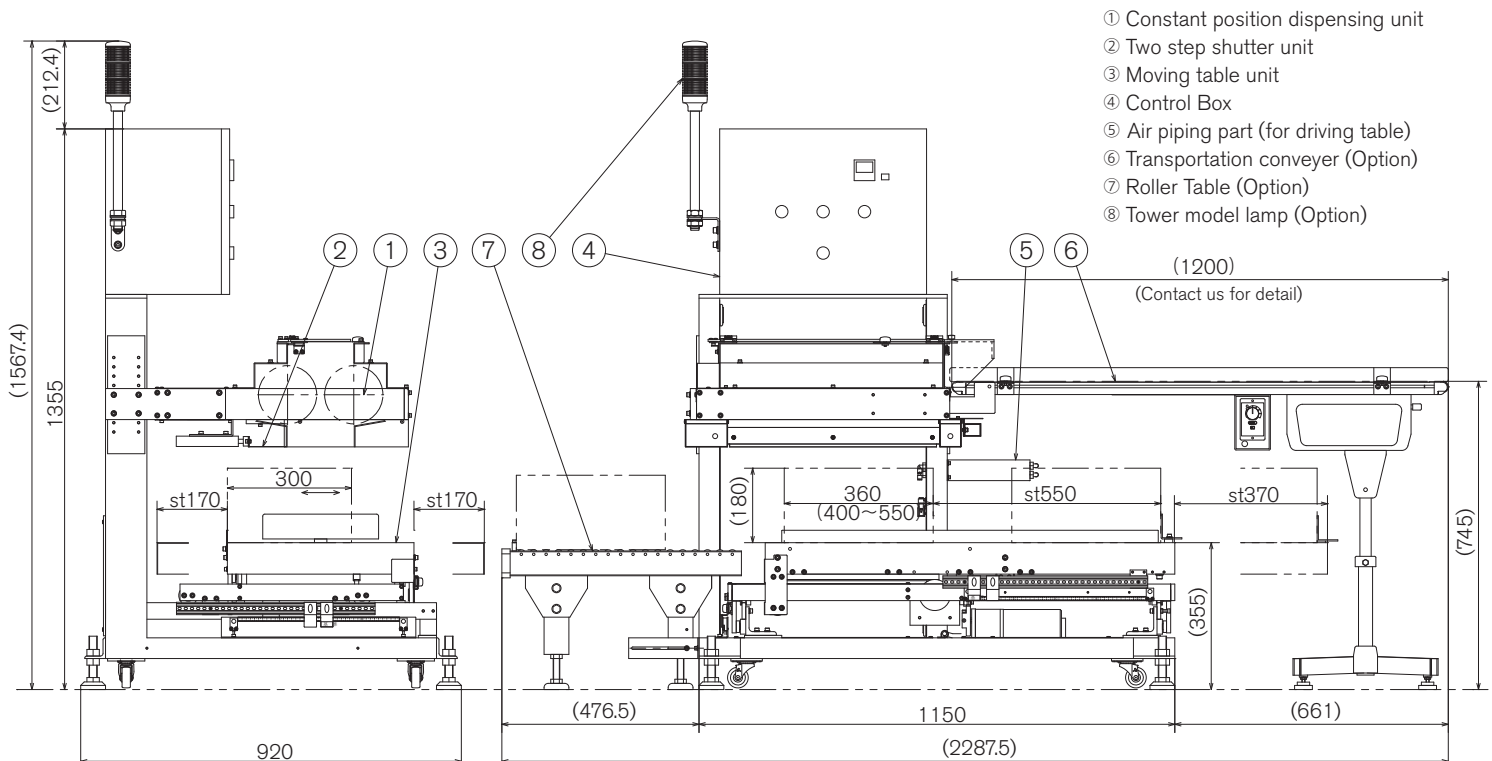

### 株式会社 三橋製作所 MITSUHASHI CORPORATION



**MITSUHASHI CORPORATION**

[www.mitsubishi-corp.co.jp](http://www.mitsubishi-corp.co.jp)  
[info@mitsubishi-corp.co.jp](mailto:info@mitsubishi-corp.co.jp)

- Head Office/  
Factory
 

1 Sekizan-cho Yamanouchi Ukyo-ku Kyoto  
615-0082 Japan  
TEL:+81-75-316-3300 FAX:+81-75-313-7595
- Tokyo Office/  
Overseas Sales Division
 

Yoshikuni Komagata Bldg. 9F 2-4-11 Komagata  
Taitoh-ku Tokyo 111-0043 Japan  
TEL:+81-3-3847-9751 FAX:+81-3-3847-9753
- Kyushu Office
 

Minamikindai Building 6F, 4-2-10 Hakataekiminami  
Hakata-ku Fukuoka 812-0016 Japan  
TEL:+81-92-476-3800 FAX:+81-92-476-3801