

KS-5000 POUCH CUTTER

*High Speed
Cutting,
Stitch-Line
Forming
Notch Forming*



Features

- High speed cutting / notching at 500pcs/minute by adopting rotary type cutter & notch blade
- Rotary twin blade system is work material friendly, reducing pin-holes.
- Cutting and stitch-line forming by single blade achieving high preparation accuracy (Patent Pending 5393753)
- Easy operation by 5.7" color touch panel
- 30 types memory-bank corresponds to wide product types

Basic Specs

Capacity	Max. 500 pcs/minute (at single pouch length under 100mm) *Capacity is to reduce as pouch length becomes longer. *Capacity is subject to change based on pouch material and/or the contents.
Pouch Size	Width: 65 – 130mm Length: 45 – 230mm Thickness: Max. 20mm
Equipment Dimension	1868mm (W) x 1945mm (H) x 870mm (D)
Power	AC200/220V, 50/60Hz, 3 Phase, 2.5kVA
Weight	Approx. 300kg

Overview

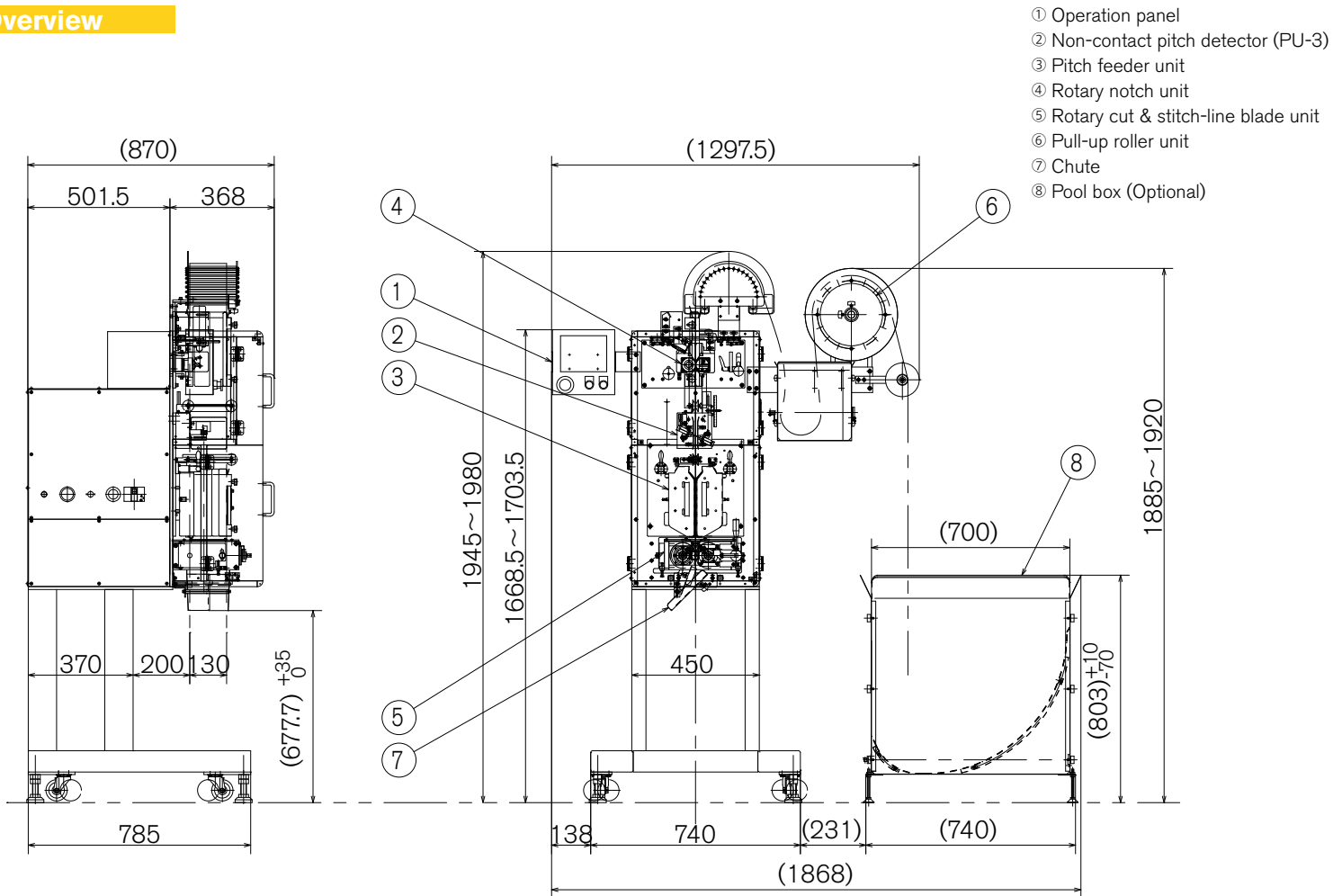

www.mitsubishi-corp.co.jp
info@mitsubishi-corp.co.jp

株式会社 三橋製作所

MITSUHASHI CORPORATION

□ Head Office/
Factory

1 Sekizan-cho Yamanouchi Ukyo-ku Kyoto
615-0082 Japan
TEL:+81-75-316-3300 FAX:+81-75-313-7595

□ Tokyo Office/
Overseas Sales Division

Yoshikuni Komagata Bldg. 9F 2-4-11 Komagata
Taitoh-ku Tokyo 111-0043 Japan
TEL:+81-3-3847-9751 FAX:+81-3-3847-9753

□ Kyushu Office

Minamikindai Building 6F, 4-2-10 Hakataekiminami
Hakata-ku Fukuoka 812-0016 Japan
TEL:+81-92-476-3800 FAX:+81-92-476-3801