

KD-4010 POUCH DISPENSER



*SACHET-FRIENDLY
CONSECUTIVE Feeding*

Features

- Consecutive high-speed operation by **Rotary Cutter**
- Capacity: **280 sachets / minute**
- Sachet feeding & cutting synchronized with packing machine
- Sachet friendly smooth movement
- Easy operation by **5.7" color touch panel**
- Register up to **30 recipes**

Basic Specs

Dispensing Capacity	280 sachets / minute
Sachet Size	Width: 50 – 100mm Length: 50 – 120mm Thickness: Max. 10mm
Sachet Type	3 seam-seal / 4 seam-seal
Cutting Accuracy	$\geq \pm 1.5\text{mm}$
Air Utility	0.5MPa 3 ℓ /min. (ANR) Dry air
Operation Atmosphere	0°C - 40°C (Humidity under 80%RH)
Weight	Approx. 210kg

* Note: This products is custom made.

Overview

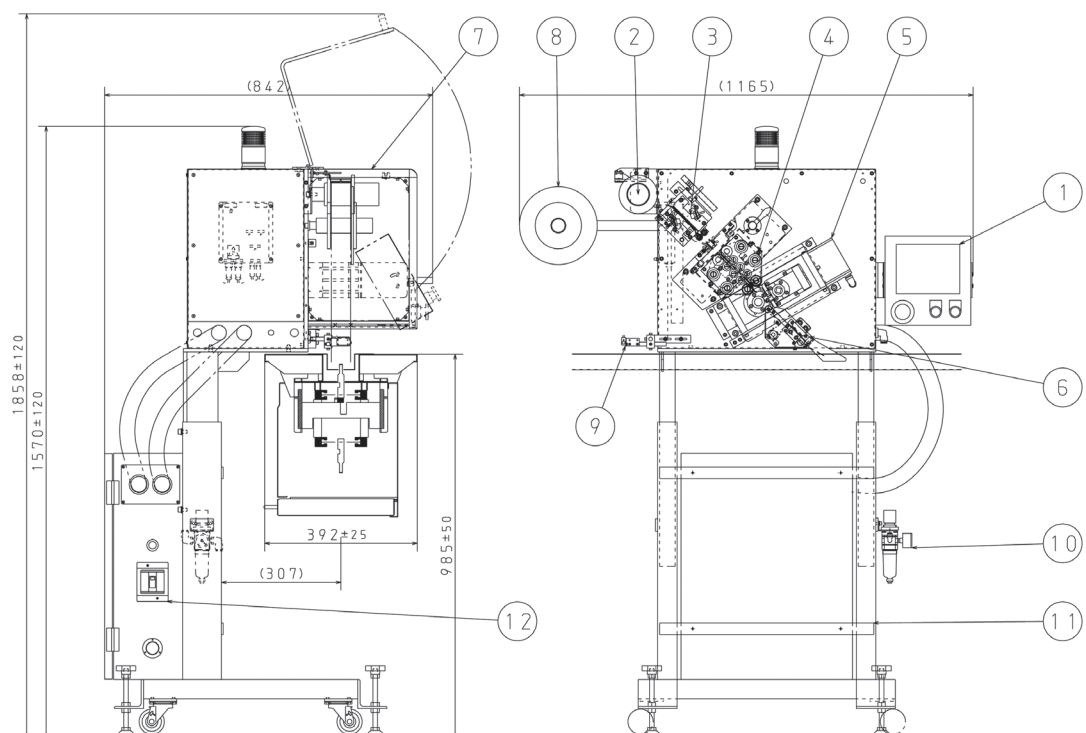

- | | | |
|------------------------|---------------------|-------------------------|
| ① Operation panel | ⑤ Cutter unit | ⑨ Noodle detection unit |
| ② Top roll unit | ⑥ Belt chute unit | ⑩ Air system |
| ③ Pitch detection unit | ⑦ Safety cover unit | ⑪ Stand frame |
| ④ Belt feed unit | ⑧ Roll unit | ⑫ Control box |



www.mitsubishi-corp.co.jp
info@mitsubishi-corp.co.jp

株式会社 三橋製作所

MITSUHASHI CORPORATION

Head Office/
Factory

1 Sekizan-cho Yamanouchi Ukyo-ku Kyoto
615-0082 Japan
TEL:+81-75-316-3300 FAX:+81-75-313-7595

Tokyo Office/
Overseas Sales Division

Yoshikuni Komagata Bldg. 9F 2-4-11 Komagata
Taitoh-ku Tokyo 111-0043 Japan
TEL:+81-3-3847-9751 FAX:+81-3-3847-9753

Kyushu Office

Minamikindai Building 6F, 4-2-10 Hakataekiminami
Hakata-ku Fukuoka 812-0016 Japan
TEL:+81-92-476-3800 FAX:+81-92-476-3801